



## Moulding Selection Guide

Midwest Edition



*Now Available!*  
Finger Joint Poplar  
Primed Mouldings!

**GREEN Mouldings!**  
*Ask for Details!*



# From Ordinary to *Extraordinary*

Turn a basic space into a masterpiece with a few simple upgrades.



**A SHOWCASED MASTERPIECE**



**ADDED DETAILS**

### A Showcased Masterpiece

- Doorway Casing - 3-3/8"
- Window Casing - 3"
- Window & Door Header Build-Up
- Crown - 3-3/8"
- Stool - 5-1/4"
- Chair Rail Build-Up
- Chair Rail Backer - 4-1/4"
- Chair Rail - 2-7/8"
- Frames (Base Cap) - 1-1/8"
- Base - 5-1/4"
- Crown Build-Up
- Base - 4-1/4"
- Crown - 4-1/4"
- Chair Rail - 2-5/8"

### Added Details

- Casing - 2-1/4"
- Plinth Block - 5-3/4"
- Corner Block - 2-1/2"
- Base - 3-1/4"
- Chair Rail - 2-5/8"
- Crown - 4-1/4"



**BASIC**

### Basic Room

- Casing - 2-1/4"
- Base - 3-1/4"

# Inspire with Build-Up Mouldings

Combine two or more profiles to create your own unique pattern, otherwise called a Build-Up. Build-ups can be elaborate or simple, highly ornate or plain, and can set a unique tone to any room. Create a unique expression with your own custom moulding as demonstrated below.

## Crown



1 - Base, 2 - Crown



1 - Base, 2 - Crown



1 - Cove, 2 - S4S, 3 - Crown

## Chair Rail



1 - Backer Bead,  
2 - Chair Rail



1 - Quarter Round, 2 - S4S,  
3 - Base, 4 - Base Cap



1 - Cove, 2 - S4S,  
3 - Chair Rail

## Casing



1 - S4S, 2 - Casing, 3 - Cove



1 - S4S, 2 - Base, 3 - Base Cap



1 - Base, 2 - Base Cap

## Baseboard



1 - Base, 2 - Stop



1 - Shoe, 2 - S4S, 3 - Base



1 - Base Cap, 2 - S4S,  
3 - Quarter Round

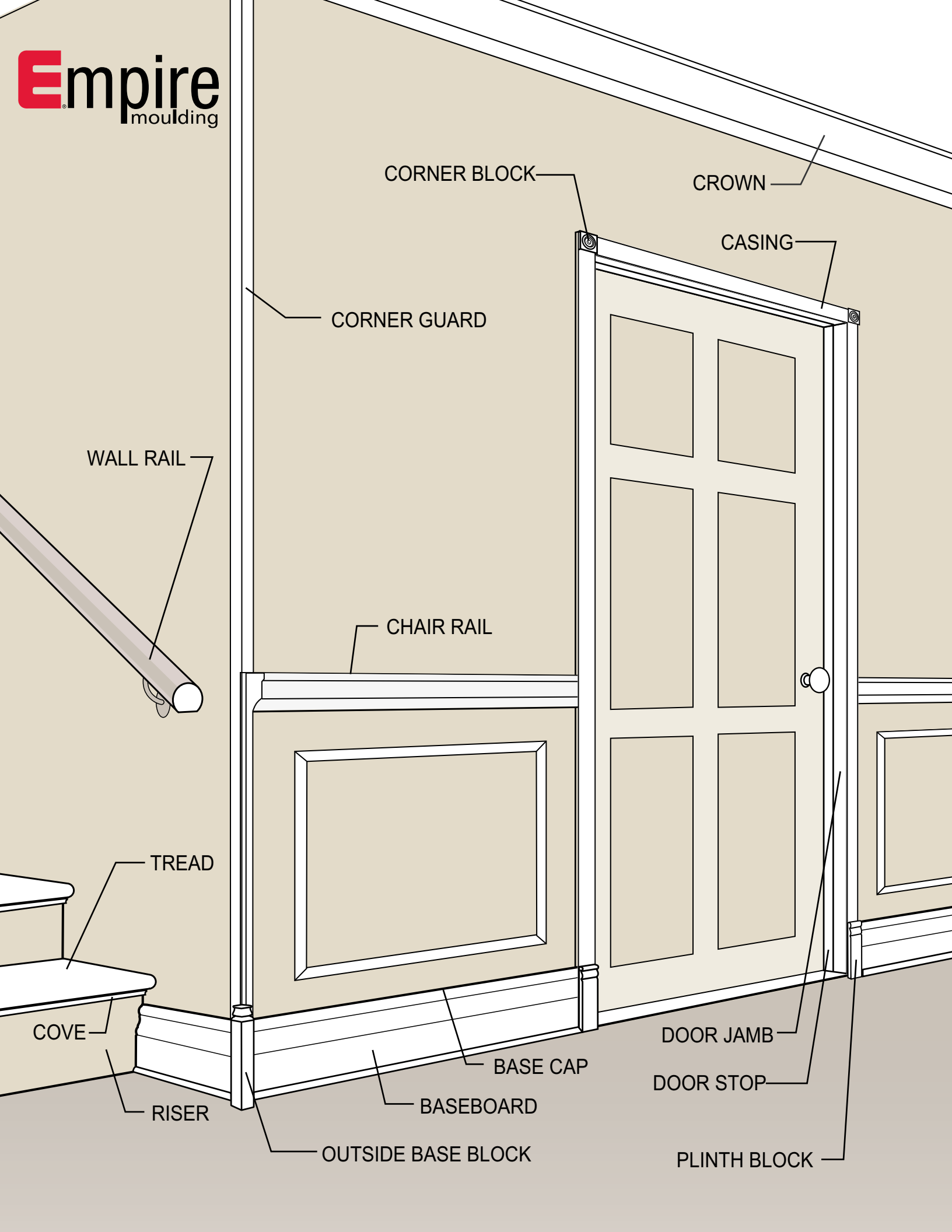

CORNER BLOCK

CROWN

CASING

CORNER GUARD

WALL RAIL

CHAIR RAIL

TREAD

COVE

RISER

OUTSIDE BASE BLOCK

BASE CAP

BASEBOARD

DOOR JAMB

DOOR STOP

PLINTH BLOCK

# Empire is going GREEN!

Complete your Earth friendly project with Certified Green Mouldings. Ask your sales representative about green products available wherever you see **GO GREEN** with Empire!



## TABLE OF CONTENTS

ROOM UPGRADES .....	2
BUILD-UP MOULDINGS .....	3
ROOM ILLUSTRATION .....	4-5
WINDOW & DOOR	
Casing .....	6-13
Mullion .....	14
Stops .....	15
Brick Mould .....	16
Shingle Mould .....	16
Drip Cap .....	16
T-Astragal .....	16
Stools .....	17
Extension Half Round .....	17
BASE	
Base .....	18-24
Shoe .....	25
Base Cap .....	25
CHAIR & WALL	
Backband .....	26
Panel Mould .....	26
Wainscoting Cap .....	26
Lip Mould .....	27
Ply Cap .....	27
Chair Rail .....	27
Backer Bead .....	27
Wainscoting .....	28
CEILING	
Cove .....	29
Bed Mould .....	29
Crown .....	29-33
GENERAL PURPOSE	
General Purpose .....	34
Rails & Poles .....	35
BOARDS & JAMBS	
Boards .....	36
Jambs .....	37
BLOCKS .....	38-39
ULTRALITE MDF .....	40-43
PRIMED FINGER JOINT POPLAR .....	44-45
HARDWOOD MOULDINGS .....	46-49
QUICK REFERENCE .....	50-58
ADDITIONAL PRODUCTS .....	59

# Key

- DFIR = Douglas Fir
- BIRVN = Birch Veneer
- FJBAR = Finger Joint Bare
- FJPMD = Finger Joint Primed
- FJPCC = Finger Joint Clay Coat
- FJPDP = Finger Joint Double Pass Primed
- PINE = Solid Pine
- SPINE = Southern Yellow Pine
- PINEV = Pine Veneer
- MAPLE = Solid Maple
- MAPV = Maple Veneer
- MDF = Ultralite MDF
- OAK = Solid Oak
- OAKVN = Oak Veneer
- POPLR = Poplar
- POPFP = Primed Finger Joint Poplar

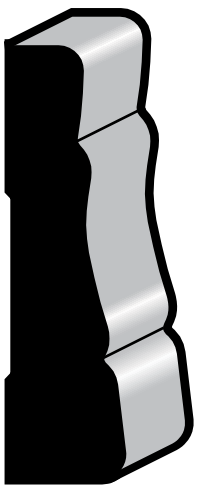

**CASING**  102 5/8 x 2-1/4 POPFP

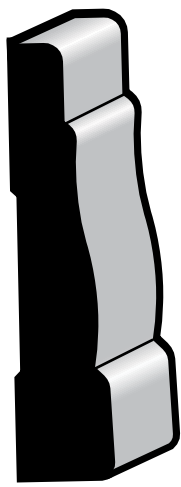

**CASING**  207 1/2 x 2-1/4 POPFP

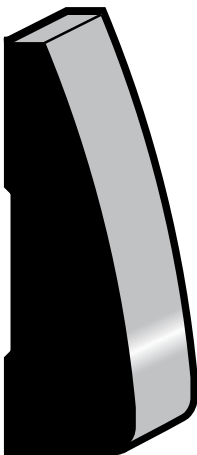

**CASING** 316 11/16 x 2-1/4 PINE, FJPMD  
5/8 x 2-1/4 OAK

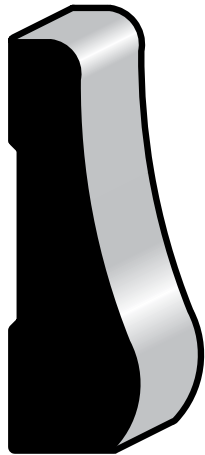

**CASING** 321 11/16 x 2-1/4 PINE

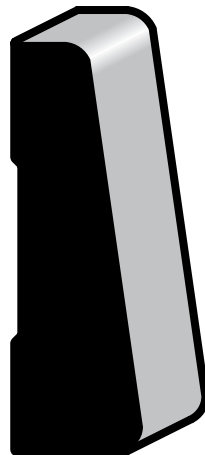

**CASING** 324 11/16 x 2-1/4 PINE, FJPMD

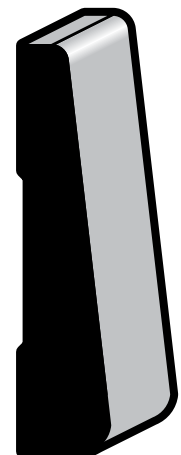

**CASING** L 324 15/32 x 2-1/4 PINE  
1/2 x 2-1/4 OAK

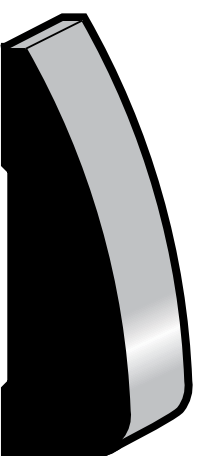

**CASING** 327 11/16 x 2-1/4 PINE, FJPMD

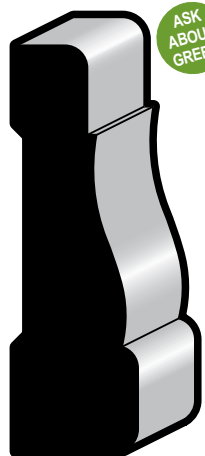

**CASING** 356 11/16 x 2-1/4 PINE, FJPMD, FJPCC  
19/32 x 2-1/4 MDF  
5/8 x 2-1/4 OAK, POPLR

ASK ABOUT GREEN

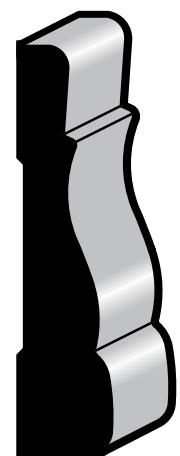

**CASING** L 356 1/2 x 2-1/4 OAK, MAPLE



**CASING**  
V 357 11/16 x 2-1/4 **OAKVN**

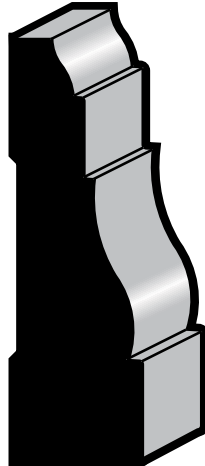

**CASING**  
366 11/16 x 2-1/4 **PINE,**  
**FJPM D,**  
**FJPCC**  
19/32 x 2-1/4 **MDF**  
5/8 x 2-1/4 **OAK,**  
**POPLR**

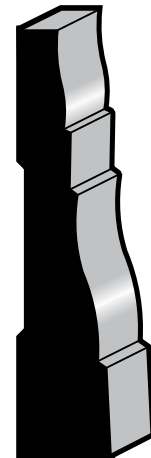

**CASING**  
L 366 1/2 x 2-1/4 **OAK**

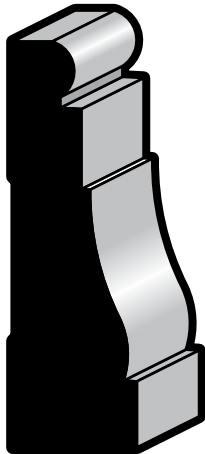

**CASING**  
376 11/16 x 2-1/4 **PINE,**  
**FJPM D**  
19/32 x 2-1/4 **MDF**

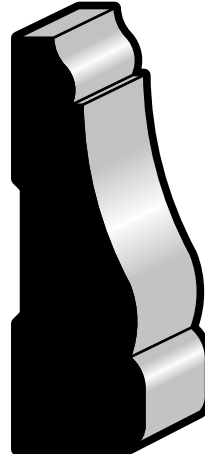

**CASING**  
442 11/16 x 2-1/4 **FJPM D**



ASK ABOUT GREEN

**CASING**  
473 9/16 x 2-1/4 **PINE,**  
**FJBAR**



**CASING**  
L 473 7/16 x 2-1/4 **FJBAR**  
19/32 x 2-1/4 **MDF**  
1/2 x 2-1/4 **OAK,**  
**POPLR**

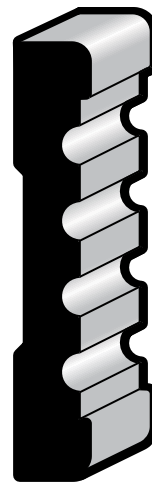

**CASING**  
8900 3/8 x 2-1/4 **OAK**

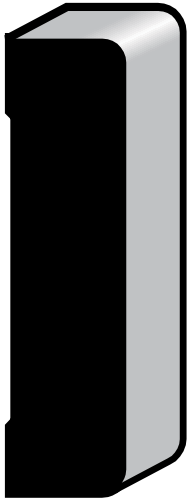

CASING 252 5/8 x 2-1/2 POPFP

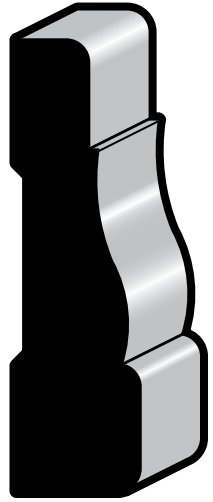

CASING 351 11/16 x 2-1/2 PINE, FJPM D

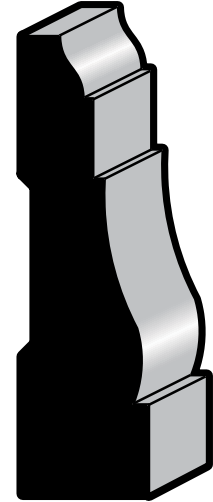

CASING 361 11/16 x 2-1/2 PINE, FJPM D, FJPCC, 19/32 x 2-1/2 MDF, 9/16 x 2-1/2 OAK

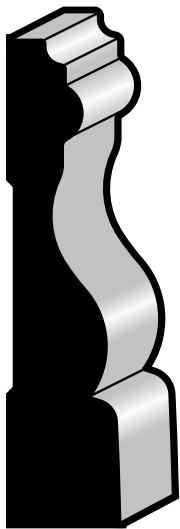

CASING 475 9/16 x 2-1/2 OAK

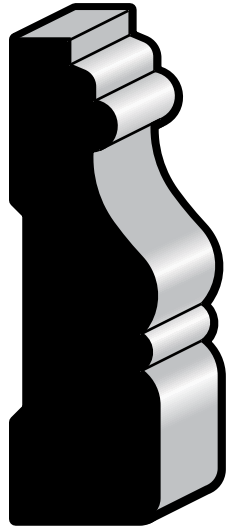

CASING 4530 3/4 x 2-1/2 OAK

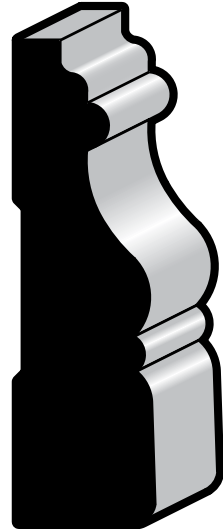

CASING 4532 11/16 x 2-1/2 MDF

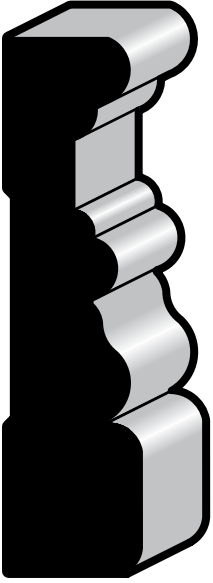

**CASING**  
P 380 11/16 x 2-3/4 PINE,  
FJPM D,  
FJPCC,  
MDF,  
POPLR

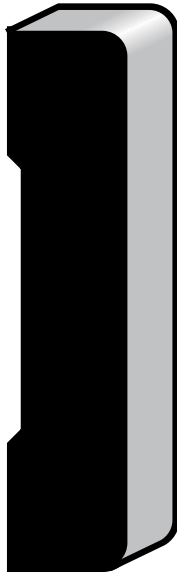

**CASING**  
L 471 19/32 x 2-3/4 MDF



**CASING**  
474 11/16 x 2-3/4 FJPCC,  
OAK,  
POPLR

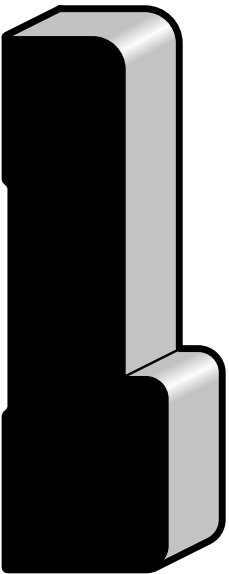

**CASING**  
685 11/16 x 2-3/4 MDF

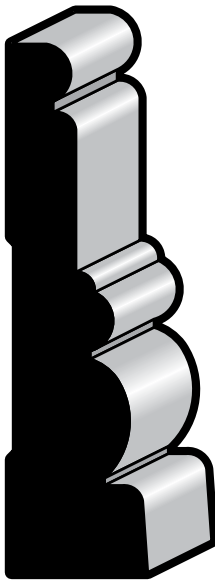

**CASING**  
4520 11/16 x 2-3/4 MDF

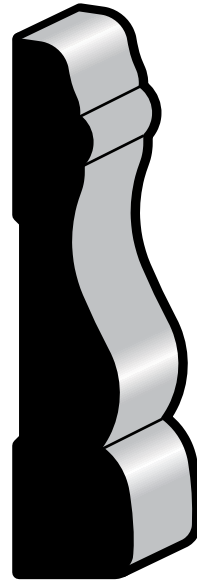

**CASING**  
7705 5/8 x 2-3/4 FJPM D

# Casing 3" - 3-1/4"

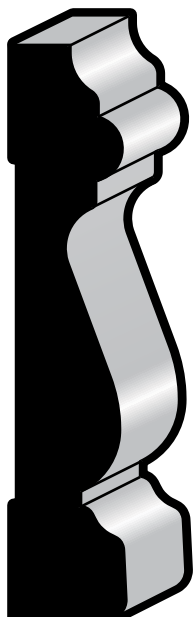

**CASING**  
312 19/32 x 3

**MDF**

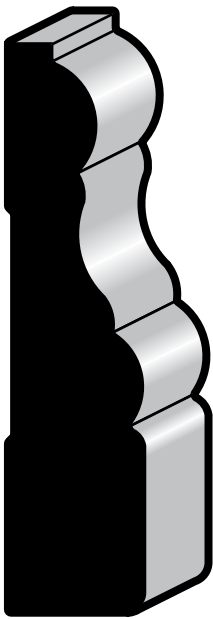

**CASING**  
411 11/16 x 3

**MDF**

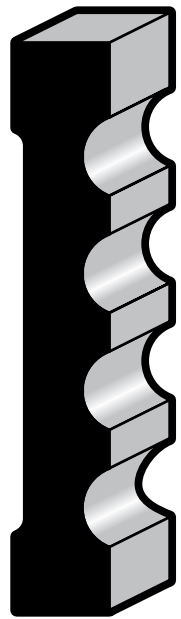

**CASING**  
8901 1/2 x 3

**OAK**

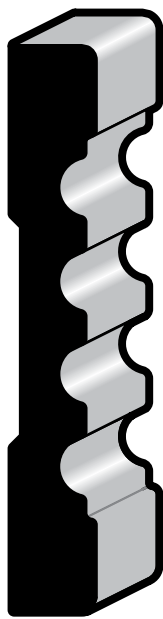

**CASING**  
L FLTD 7/16 x 3

**PINE**

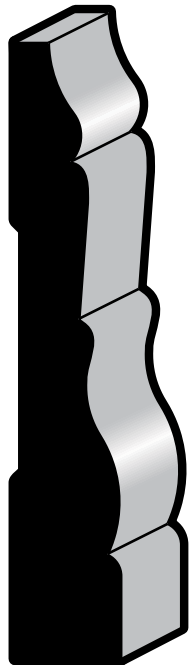

**CASING**  
40 9/16 x 3-1/4

**OAK**

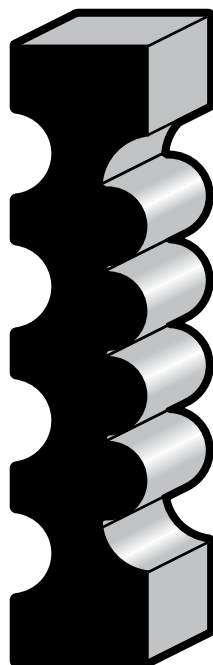

**CASING**  
195 11/16 x 3-1/4

**OAK**

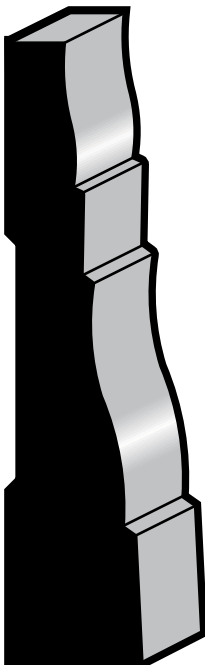

**CASING**  
L 366 11/16 x 3-1/4

**FJPM, FJPC**

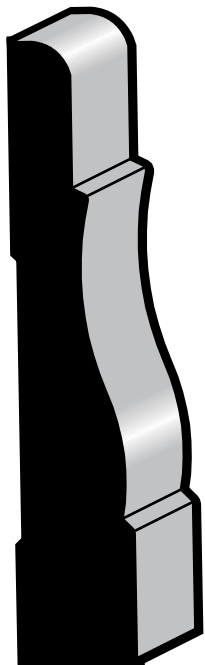

**CASING**  
193 5/8 x 3-1/4



**POPFP**

ASK ABOUT GREEN

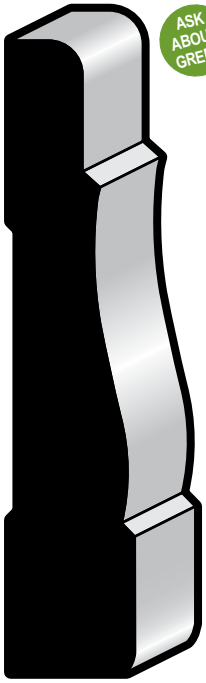

**CASING**  
L 444 11/16 x 3-1/4

PINE,  
FJPM D,  
FJPCC,  
POPLR  
MDF  
OAK,  
MAPLE

19/32 x 3-1/4  
3/4 x 3-1/4

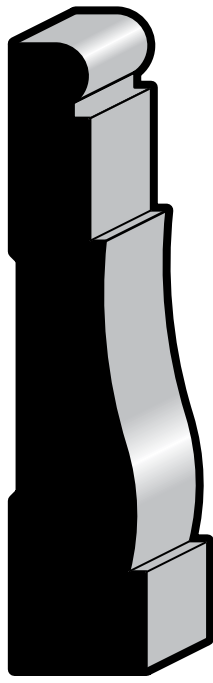

**CASING**  
445 11/16 x 3-1/4

PINE,  
FJPM D,  
FJPCC  
MDF

19/32 x 3-1/4

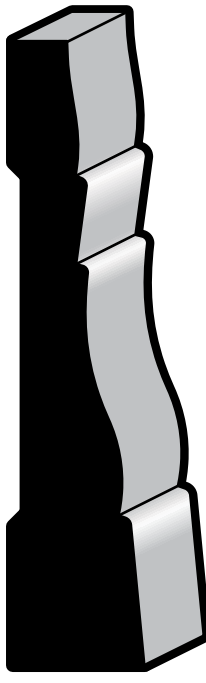

**CASING**  
L 367 11/16 x 3-1/4 PINE

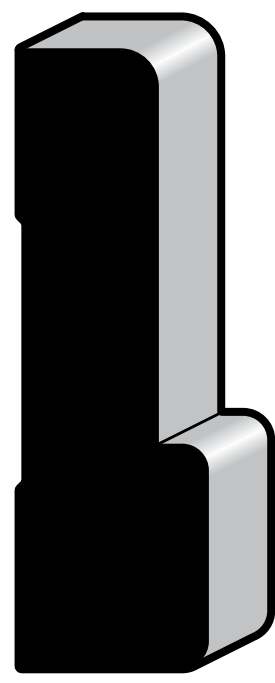

**CASING**  
682 1 x 3-1/4 MDF

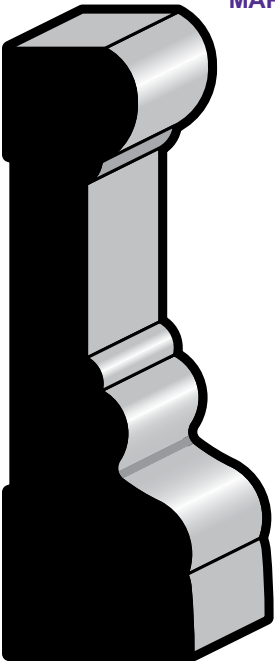

**CASING**  
PT3 1 x 3-1/4 MDF



**CASING**  
8296 11/16 x 3-1/4 PINE

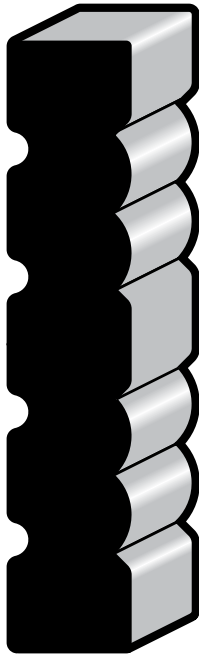

**CASING**  
REV 5/8 x 3-1/4 PINE



**CASING**  
8063 11/16 x 3-1/4 MDF

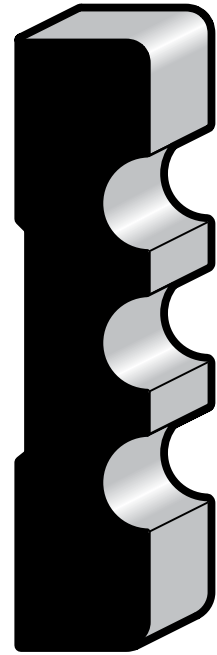

**CASING**  
FLTD 11/16 x 3-1/4 FJPM D

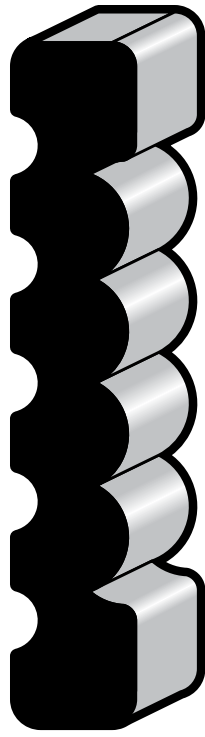

**CASING**  
338 19/32 x 3-3/8 **MDF**

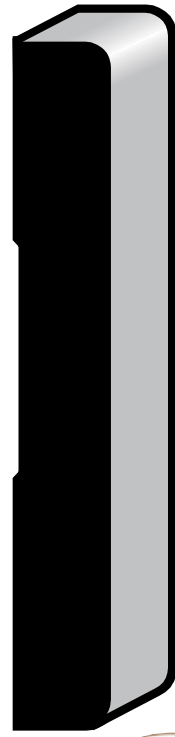

**CASING**  **POPFP**  
254 1/2 x 3-1/2

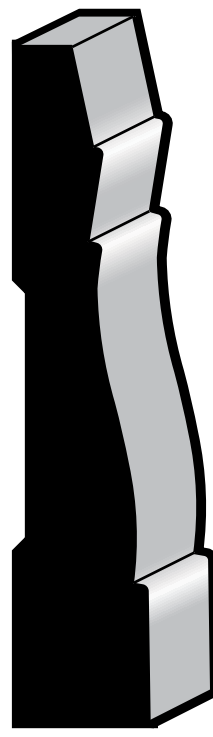

**CASING**  
L 361 11/16 x 3-1/2 **PINE, FJPM D**

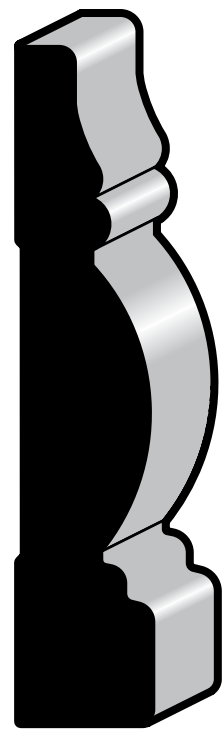

**CASING**  
374 11/16 x 3-1/2 **FJPCC, MDF, OAK**  
3/4 x 3-1/2

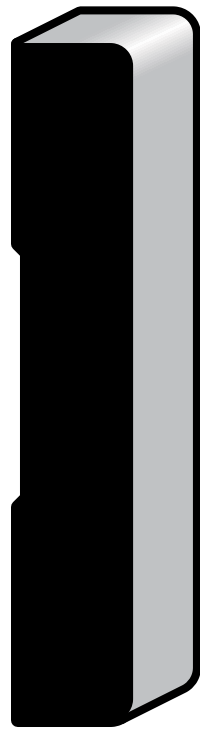

**CASING**  
412 19/32 x 3-1/2 **MDF**



**CASING**  
432 9/16 x 3-1/2 **FJPD P**

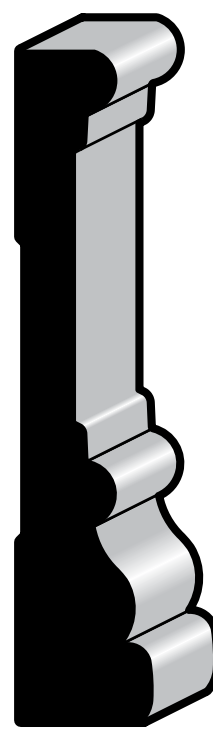

**CASING**  
P 450 11/16 x 3-1/2 **FJPM D, FJPCC, POPLR**

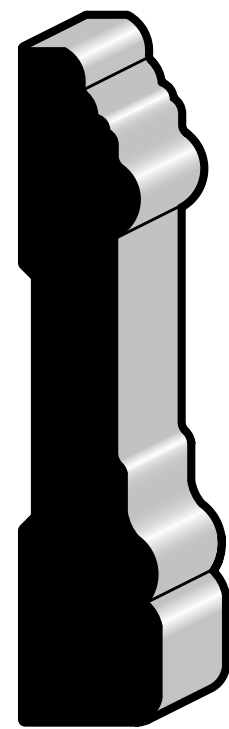

**CASING**  
535 11/16 x 3-1/2 **MDF**

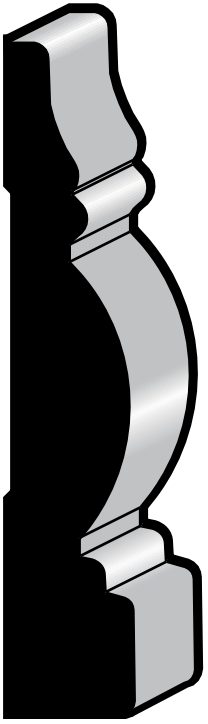

**CASING**  719 11/16 x 3-1/2 POPFP

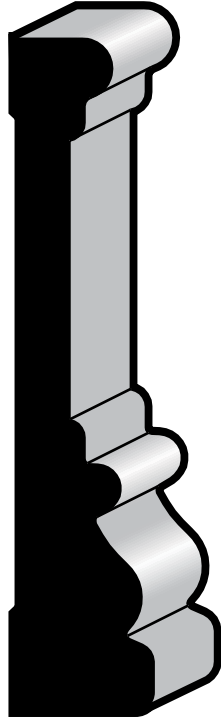

**CASING**  722 3/4 x 3-1/2 POPFP

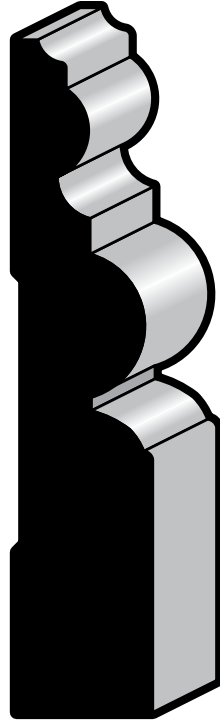

**CASING** 4555 11/16 x 3-1/2 MDF

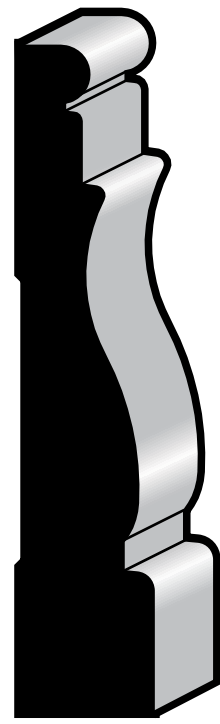

**CASING**  1942 11/16 x 3-1/2 POPFP

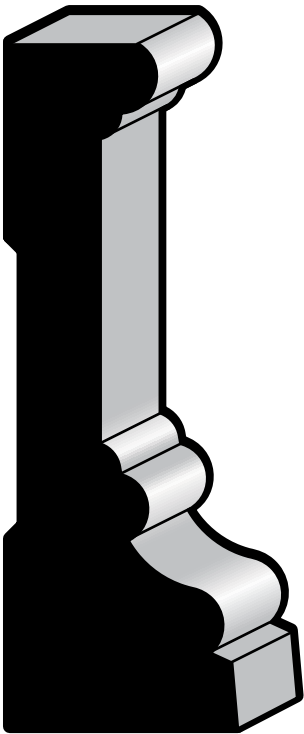

**CASING** LPT3 1-3/16 x 3-9/16 FJPCC

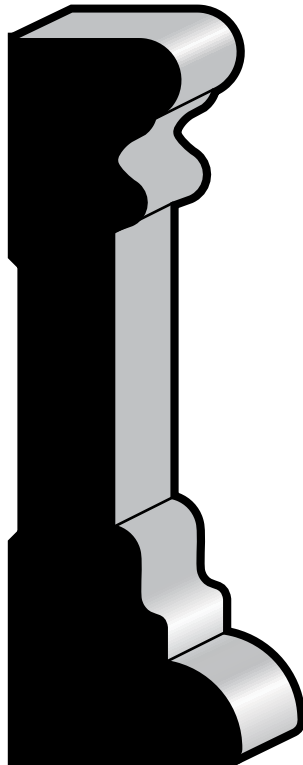

**ARCHITRAVE / CASING** 5000 1-3/16 x 3-3/4 MDF

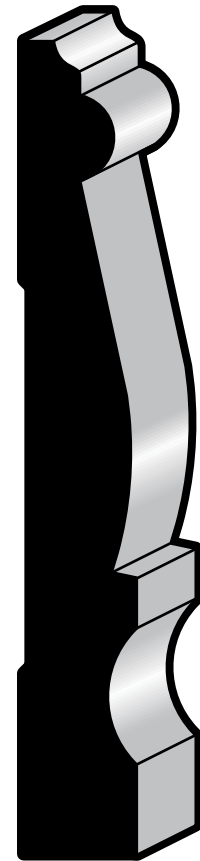

**CASING** 284 19/32 x 4-1/4 MDF

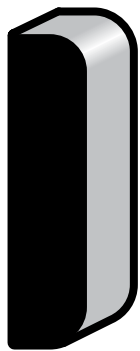

**MULLION**  
L 973 3/8 x 1-5/8 PINE

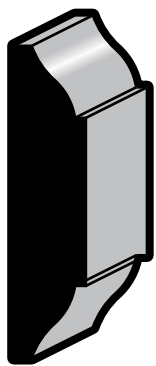

**MULLION**  
L 983 3/8 x 1-5/8 PINE

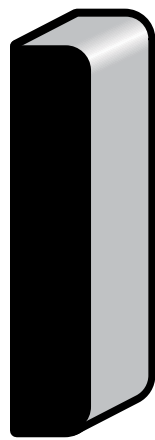

**MULLION**  
972 3/8 x 2 PINE

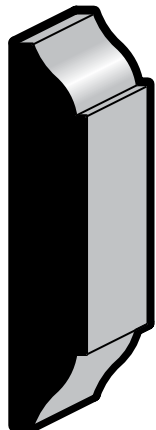

**MULLION**  
982 3/8 x 2 PINE

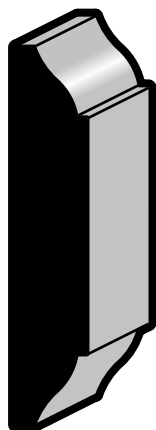

**MULLION**  
L 982 1/2 x 2 OAK



**MULLION**  
493 7/16 x 2-1/4 PINE



**MULLION**  
962 1/4 x 2-1/4 OAK



**MULLION**  
960 3/16 x 4 OAK

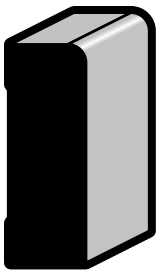

**STOP**  
878 7/16 x 1-1/8 **FJPM**D

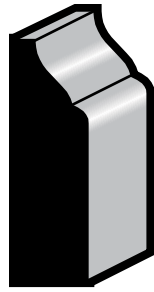

**STOP**   
402 3/8 x 1-1/4 **POPFP**



**STOP**   
403 3/8 x 1-1/4 **POPFP**



**STOP**  
857 3/8 x 1-1/4 **PINE**

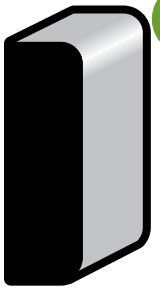

ASK ABOUT GREEN

**STOP**  
L 887 3/8 x 1-1/4 **PINE, MDF, OAK, POPLR**

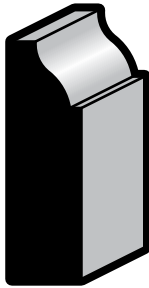

**STOP**  
947 3/8 x 1-1/4 **PINE, FJPM**D, **FJPD**P, **OAK, POPLR, MAPLE**

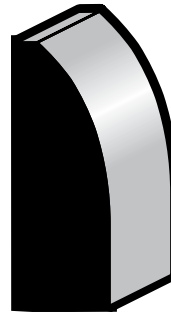

**STOP**  
846 7/16 x 1-3/8 **PINE, OAK**



**STOP**  
856 3/8 x 1-3/8 **PINE, FJPM**D



**STOP**  
L 876 7/16 x 1-3/8 **FJPM**D

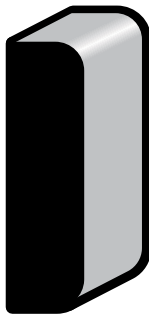

**STOP**  
L 886 3/8 x 1-3/8 **OAK**

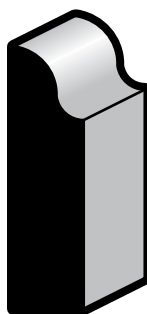

**STOP**  
916 3/8 x 1-3/8 **OAK**

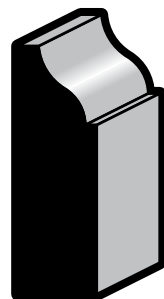

**STOP**  
936 7/16 x 1-3/8 **PINE, FJPC**C, **FJPD**P, **OAK, POPLR**

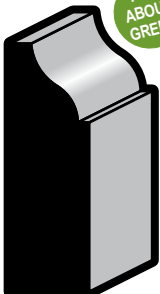

ASK ABOUT GREEN

**STOP**  
946 3/8 x 1-3/8 **PINE, MDF**

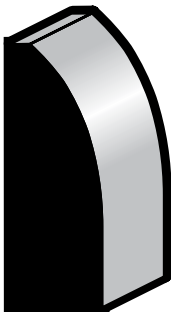

**STOP**  
845 7/16 x 1-5/8 **PINE**

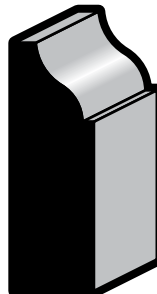

**STOP**  
935 7/16 x 1-5/8 **PINE**

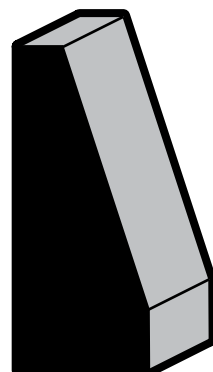

**STOP - BI FOLD**  
B FOLD 3/4 x 1-3/8 **PINE**  
3/4 x 1-5/8 **OAK**

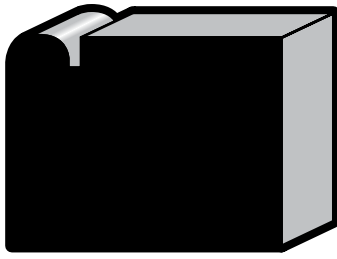

**BRICK MOULD**  
L 177 1-1/16 x 1-5/8 FJBAR

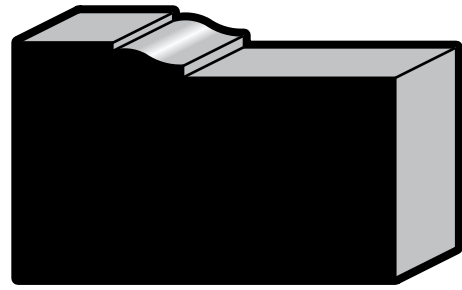

**BRICK MOULD**  
180 1-1/4 x 2 FJPM, FJBAR



**SHINGLE MOULD**  
L 210 5/8 x 1-5/8 PINE, FJPM

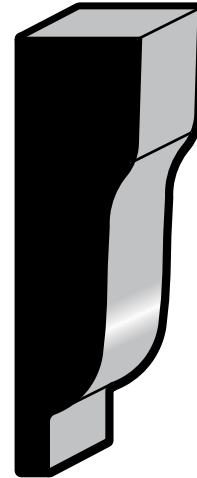

**SHINGLE MOULD**  
E 208 5/8 x 2-1/4 FJPM

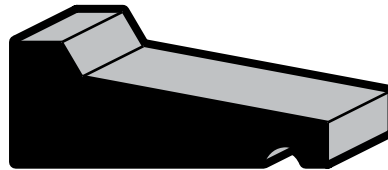

**DRIP CAP**  
L 197 5/8 x 1-5/8 PINE, FJPM

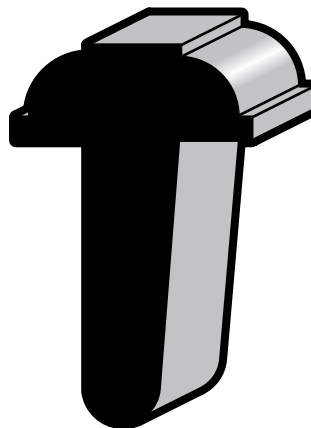

**T-ASTRAGAL**  
1305 1-1/4 x 2 PINE



**STOOL**  
N/L 11/16 x 2-1/4 PINE



**STOOL**  
1155 11/16 x 2-1/2 PINE



**STOOL**  
1153 11/16 x 3-1/4 PINE



**STOOL**  
1021 11/16 x 5-1/4 PINE,  
MDF



**EXTENDED HALF ROUND**  
E 1035 1/2 x 1-3/8 POPLR

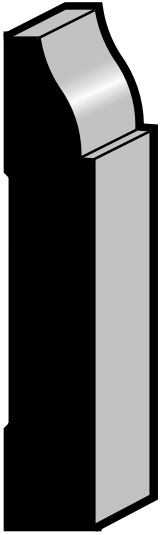

**BASE**  
L 627 7/16 x 2-1/2 PINE

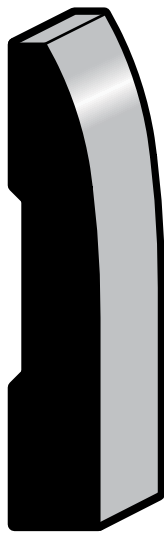

**BASE**  
L 717 7/16 x 2-1/2 PINE

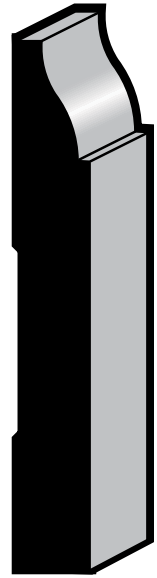

**BASE**  
L 634 7/16 x 3  
3/8 x 2-3/4



**BASE**  
L 724 7/16 x 3  
3/8 x 2-3/4

PINE,  
FJPM D,  
FJPCC  
OAK,  
MAPLE

PINE,  
FJPM D  
OAK

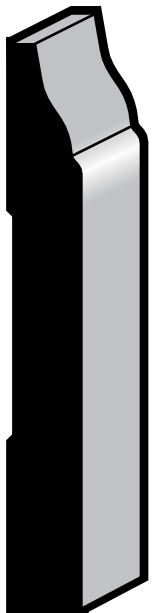

**BASE**  
312 3/8 x 3 POPFP

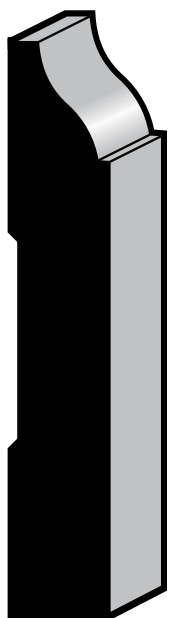

**BASE**  
634 1/2 x 3 OAK

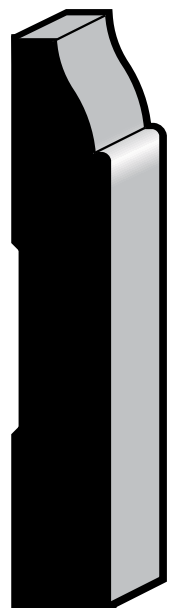

**BASE**  
H 634 1/2 x 3 OAK,  
POPLR



**BASE**  
L 635 3/8 x 3 **OAK**

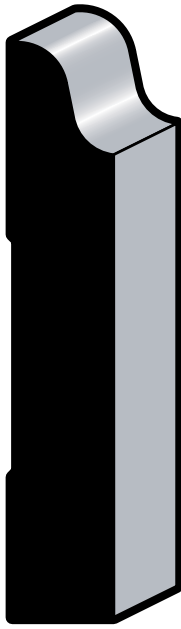

**BASE**  
664 9/16 x 3 **PINE**

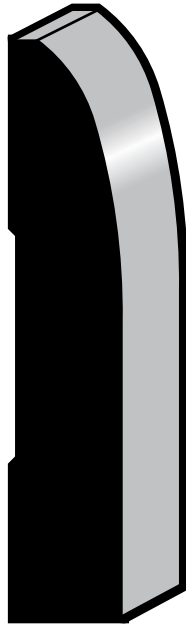

**BASE**  
714 9/16 x 3 **PINE**



**BASE**  
724 1/2 x 3 **OAK**

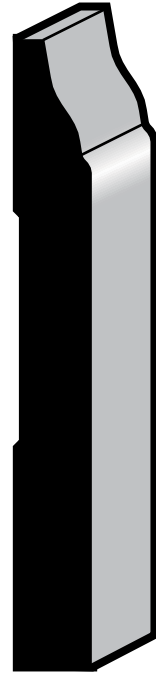

**BASE**   
322 3/8 x 3-1/4 **POPPF**



ASK ABOUT GREEN

**BASE**  
L 433 7/16 x 3-1/4

1/2 x 3-1/4  
3/8 x 3

**PINE,**  
**FJBAR**  
**MDF**  
**OAK,**  
**POPLR**

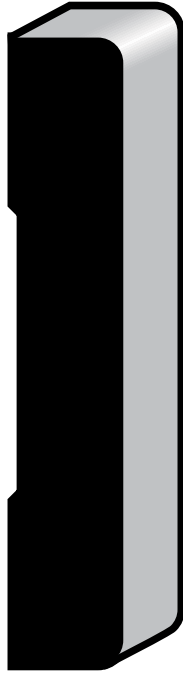

ASK ABOUT GREEN

**BASE**  
433 9/16 x 3-1/4 **FJBAR**



**BASE**  
623 9/16 x 3-1/4

1/2 x 3-1/4

**PINE,**  
**FJPMDF,**  
**FJPCC**  
**OAKVN**  
**MDF**



**BASE**  
L 623 3/8 x 3-1/4 **POPLR**

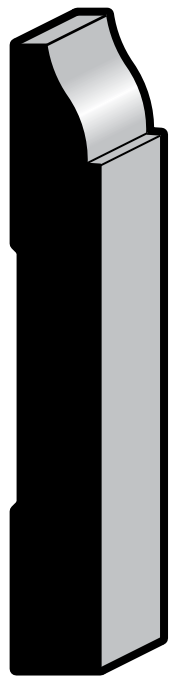

**BASE**  
L 633 7/16 x 3-1/4 PINE,  
FJPM D,  
FJPCC

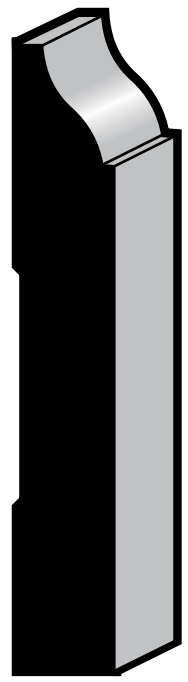

**BASE**  
633 1/2 x 3-1/4 OAK



**BASE**  
H 633 1/2 x 3-1/4 OAK,  
POPLR



**BASE**  
663 9/16 x 3-1/4 PINE,  
FJPM D,  
FJPCC  
1/2 x 3-1/4 MDF

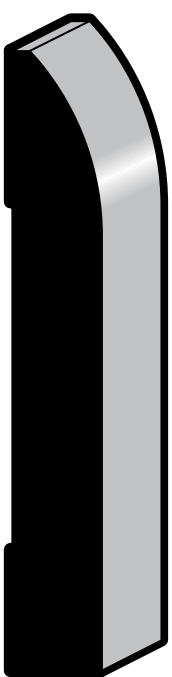

**BASE**  
713 9/16 x 3-1/4 PINE,  
FJPM D,  
1/2 x 3-1/4 MDF

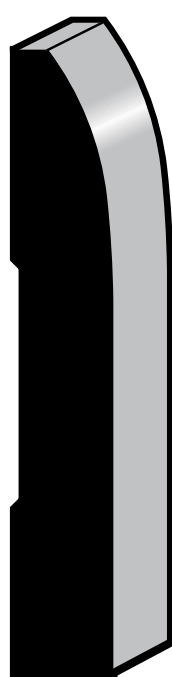

**BASE**  
723 1/2 x 3-1/4 OAK

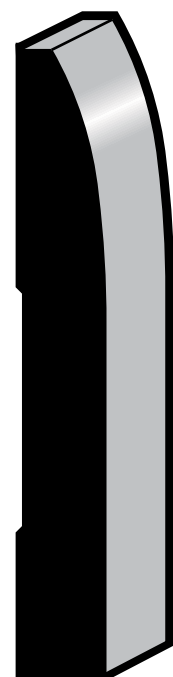

**BASE**  
L 723 7/16 x 3-1/4 PINE



**BASE**  
P 805 9/16 x 3-1/4 FJPM D,  
FJPCC  
1/2 x 3-1/4 POPLR

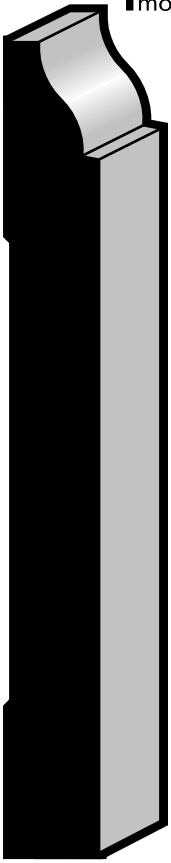

**BASE**   
353 1/2 x 4-1/4



**BASE**   
POPFP 355 3/8 x 4-1/4

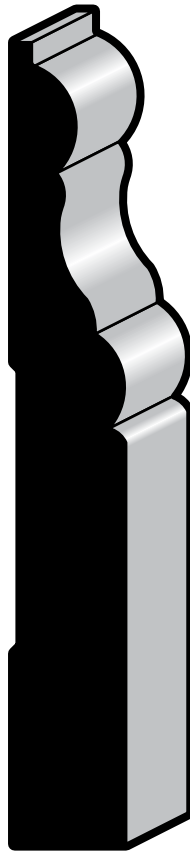

**BASE**  
POPFP 410 19/32 x 4-1/4

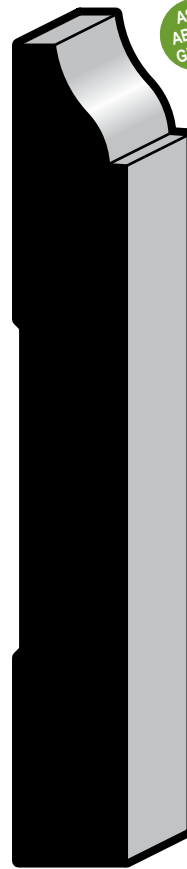

ASK ABOUT GREEN

**BASE**  
MDF 620 9/16 x 4-1/4 PINE, FJPM D, FJPCC  
1/2 x 4-1/4 **MDF**



**BASE**  
L 620 1/2 x 4-1/4



**BASE**  
POPLR, 675 1/2 x 4-1/4  
**OAK**

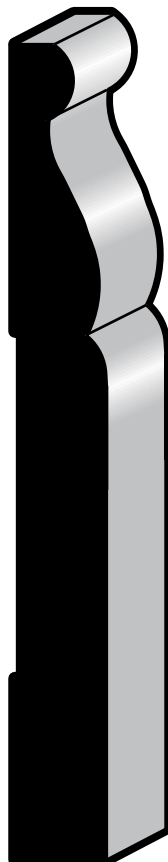

**BASE**  
P 808 9/16 x 4-1/4  
**OAK** PINE, FJPM D, FJPCC  
1/2 x 4-1/4 **MDF, OAK, POPLR, MAPLE**



**BASE**   
760 7/16 x 4-1/4 POPFP

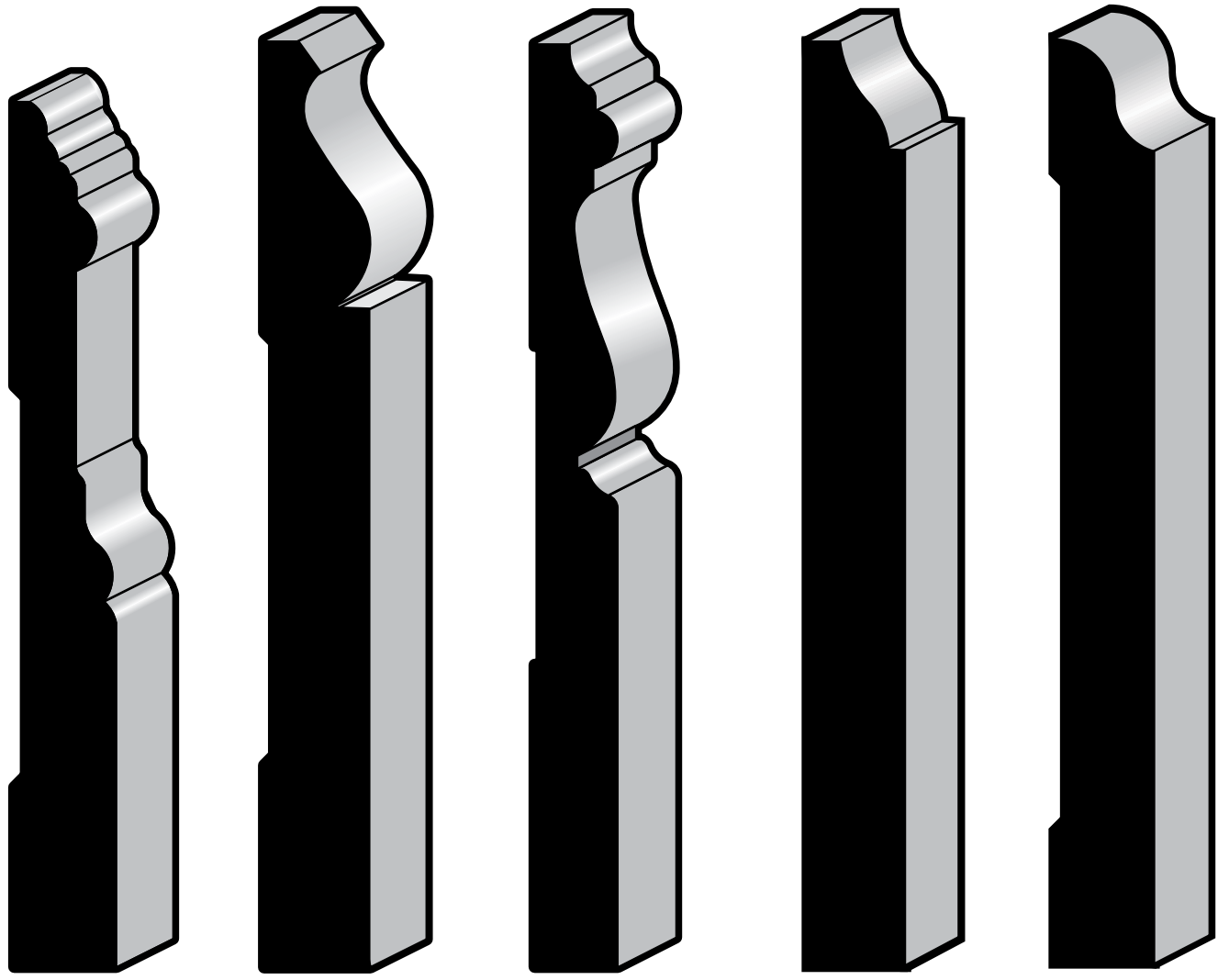

**BASE** 545 19/32 x 5 **MDF**    
 **BASE** 163E 19/32 x 5-1/4 **MDF**    
 **BASE** B 312 19/32 x 5-1/4 **MDF**    
 **BASE** 618 9/16 x 5-1/4 **PINE**, 658 9/16 x 5-1/4 **FJPMDF**  
**FJPCC**

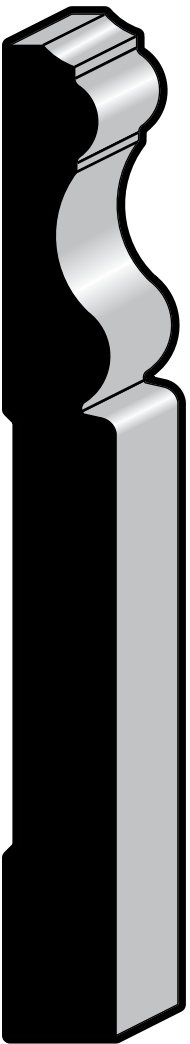

**BASE**  
674 9/16 x 5-1/4 **FJPCC**  
1/2 x 5-1/4 **OAK**

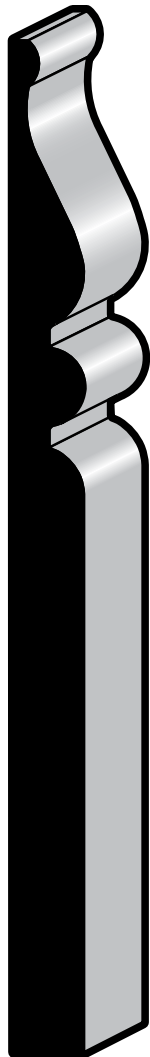

**BASE**  
695 1/2 x 5-1/4 **OAK**

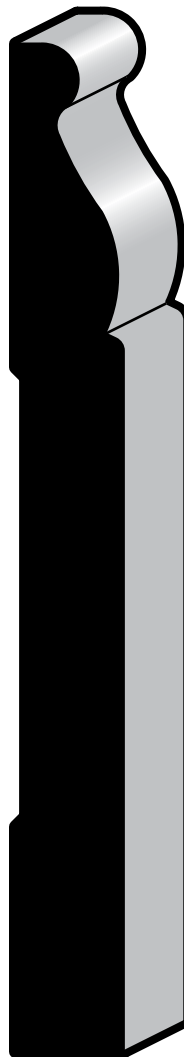

**BASE**  
P 813 9/16 x 5-1/4 **PINE,**  
**FJPMD,**  
**FJPCC**  
1/2 x 5-1/4 **MDF**

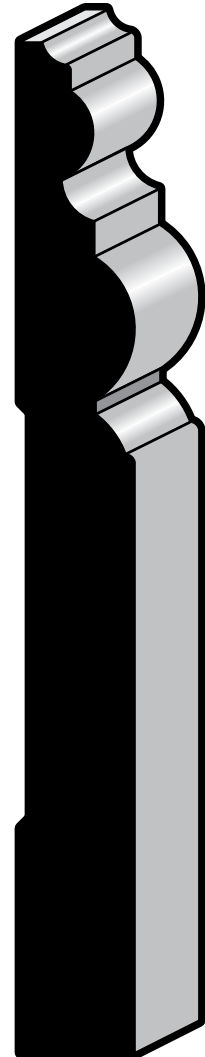

**BASE**  
7055 19/32 x 5-1/4 **MDF**

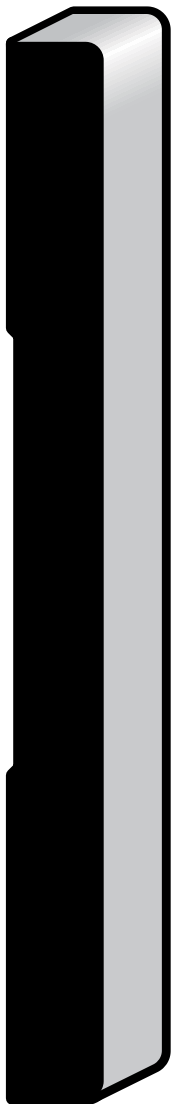

**BASE**  
512 1/2 x 5-1/2 **MDF**

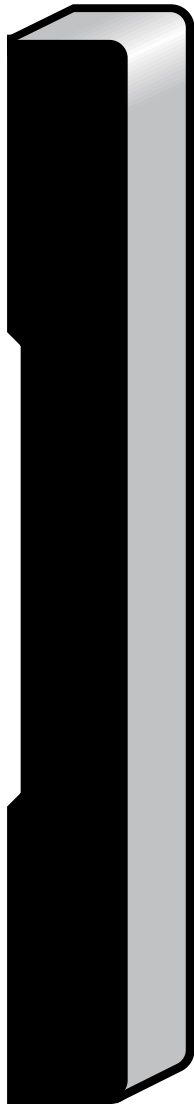

**BASE**  
L 512 19/32 x 5-1/2 **MDF**



**BASE**  
8263 19/32 x 6-1/2 **MDF**



**BASE**  
7163 19/32 x 7-1/4 **MDF**

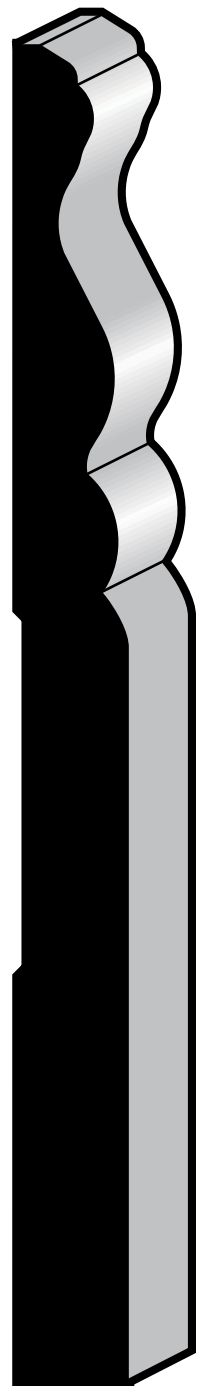

**BASE**  
207 19/32 x 7-1/4 **MDF**



ASK ABOUT GREEN

**SHOE**



21 7/16 x 3/4  
126 1/2 x 3/4

POPFP  
PINE,  
FJPM D,  
OAK,  
POPLR,  
MAPLE  
PINE,  
FJPM D

129 7/16 x 11/16

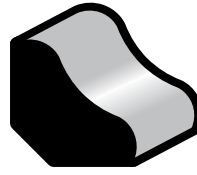

**CLOVER LEAF SHOE**

34 3/4 x 3/4 PINE,  
OAK

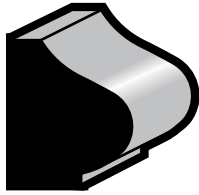

**BASE CAP**

172 5/8 x 3/4

OAK



**BASE CAP**

L 167 5/8 x 1-1/8 PINE

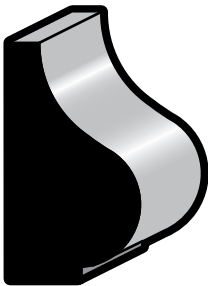

**BASE CAP**

166 11/16 x 1-1/4

PINE,  
FJPM D



**BASE CAP**

163 11/16 x 1-3/8 POPLR

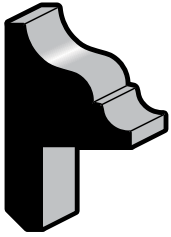

**BACK BAND**  
E 282 1-7/8 x 1-1/8 POPLR

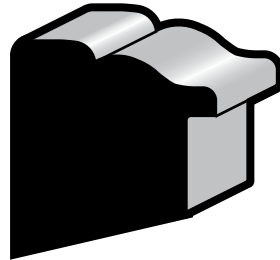

**BACK BAND**  
283 1-1/16 x 1-1/8 POPLR,  
OAK

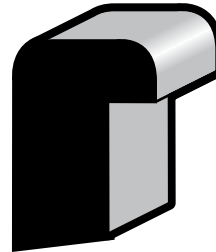

**BACK BAND**  
280 11/16 x 1-1/16 PINE

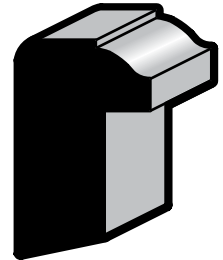

**BACK BAND**  
281 11/16 x 1-1/8 PINE



**PANEL MOULD**  
183 9/16 x 1-1/8 PINE



**PANEL MOULD**  
185 9/32 x 1-3/8 PINE

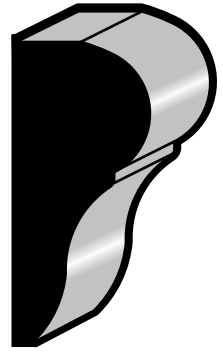

**PANEL MOULD**  
262 11/16 x 1-9/16 OAK

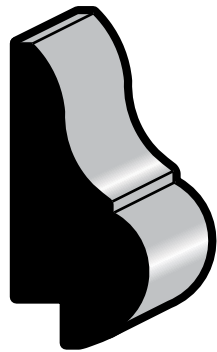

**PANEL MOULD**  
263 11/16 x 1-9/16 OAK



**PANEL MOULD**  
182 11/16 x 1-5/8 FJPM D

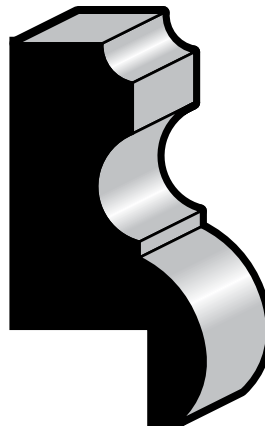

**PANEL MOULD**  
190 1 x 2 POPLR

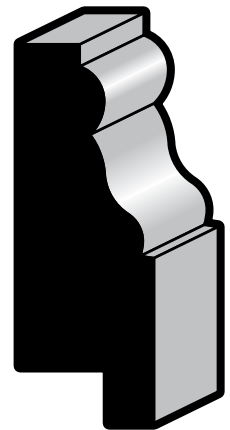

**WAINSCOTING CAP**  
WCAP 11/16 x 2 MDF



**LIP MOULD**  
158 3/4 x 1-5/8 **OAK**



**PLY CAP**  
292 9/16 x 1-1/8 **PINE**  
1/2 x 1-1/16 **OAK**



**CAP**  
L 294 11/16 x 1-1/16 **OAK**

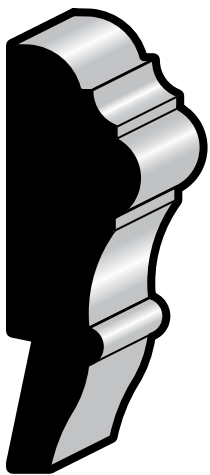

**CHAIR RAIL**  
391 11/16 x 2-1/4 **PINE**



**CHAIR RAIL**  
390 11/16 x 2-5/8 **PINE,**  
**FJPMDF,**  
**FJPCC**  
19/32 x 2-5/8 **MDF**  
5/8 x 2-5/8 **OAK,**  
**POPLR**

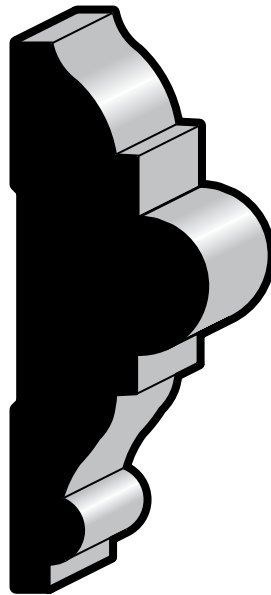

**CHAIR RAIL**  
L 300 1 x 2-7/8 **MDF**

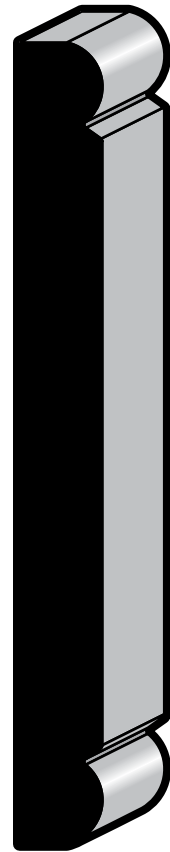

**BACKER BEAD**  
956W 1/2 x 4-1/4 **MDF**

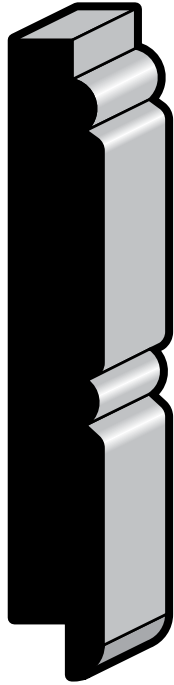

**WAINSCOTING**  
WC14 1/2 x 3-5/16 **MDF**



**WAINSCOTING**  
LWP4 19/32 x 5 **MDF**

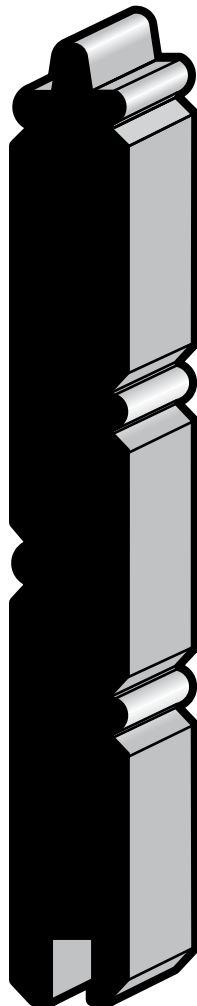

**WAINSCOTING**  
WC16 19/32 x 5 **MDF**

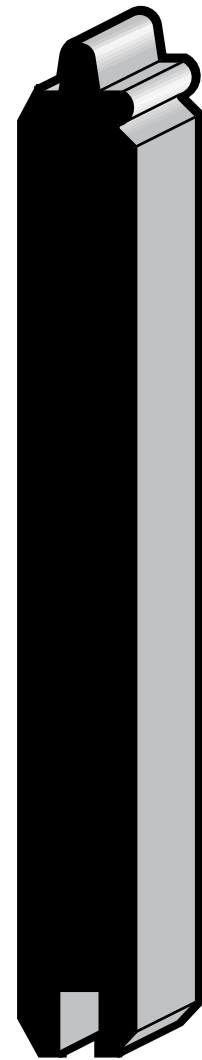

**WAINSCOTING**  
SBW4 19/32 x 5-1/4 **MDF**

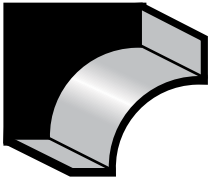

**COVE**  
93 3/4 x 3/4 **PINE, MAPLE, OAK**  
100 11/16 x 11/16 **PINE, POPLR**  
101 1/2 x 1/2 **PINE**

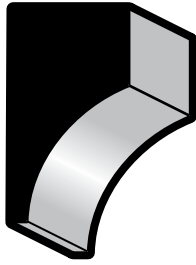

**COVE**  
L 94 5/8 x 1-1/8 **PINE**

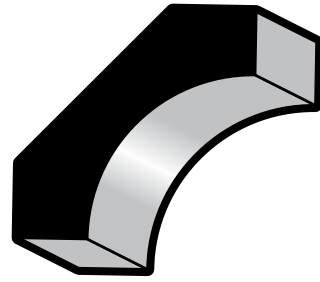

**COVE**  
84 9/16 x 2-1/4 **PINE**  
85 9/16 x 1-3/4 **PINE**  
86 9/16 x 1-5/8 **PINE**

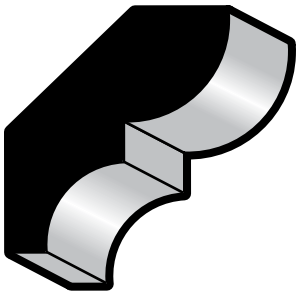

**BED**  
75 9/16 x 1-5/8 **PINE**

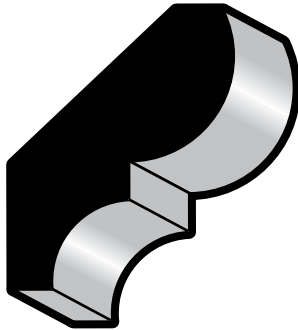

**BED**  
74 9/16 x 1-3/4 **PINE, FJPM**

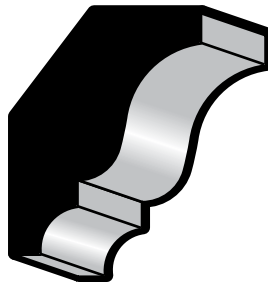

**CROWN**  
68 9/16 x 1-5/8 **PINE**  
L 68 5/8 x 1-5/8 **OAK**

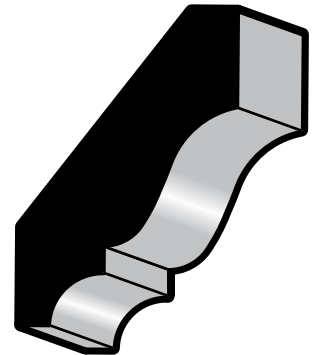

**CROWN**  
54 9/16 x 2-1/4 **PINE, FJPM**

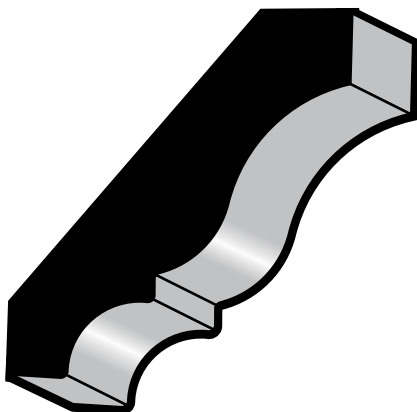

**CROWN**  
L 54 1/2 x 2-1/4 **OAK**

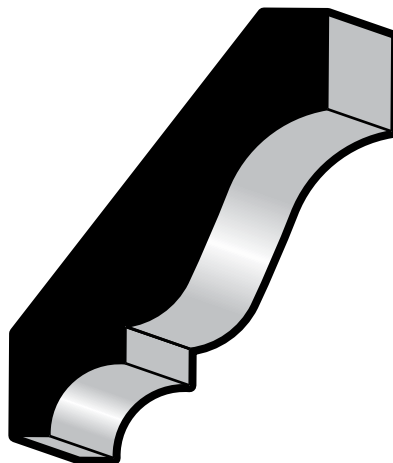

**CROWN**  
52 9/16 x 2-3/4 **PINE, OAK**  
1/2 x 2-3/4

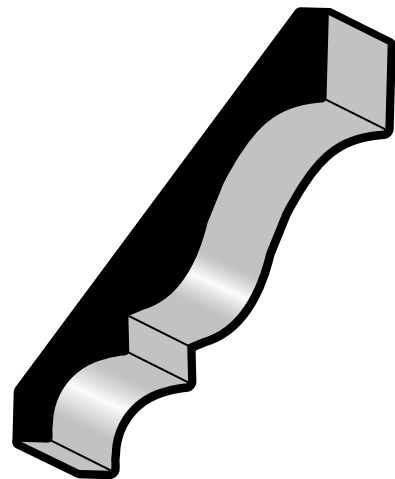

**CROWN**  
L 52 3/8 x 2-3/4 **OAK**

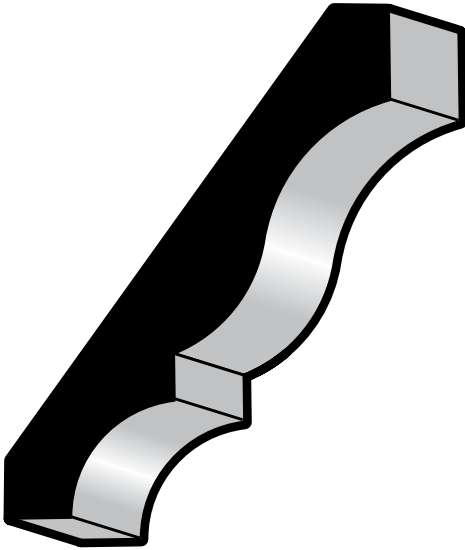

**CROWN**  
51 1/2 x 3-1/4 **OAK**

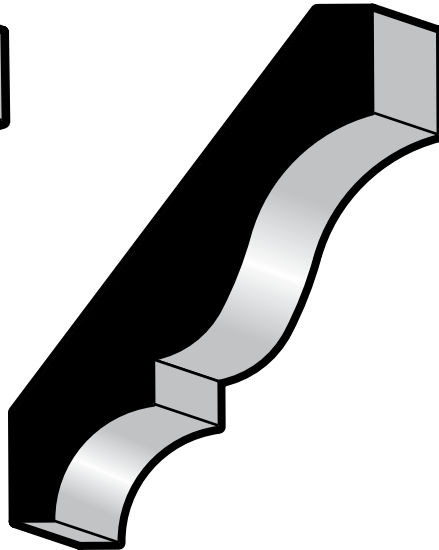

**CROWN**  
L 51 9/16 x 3-1/4 **PINE,**  
**FJPM D,**  
**FJPCC,**  
**FJPD P,**  
**POPLR**  
1/2 x 3-1/4 **MAPLE**  
V 51 5/8 x 3-1/4 **OAKVN**

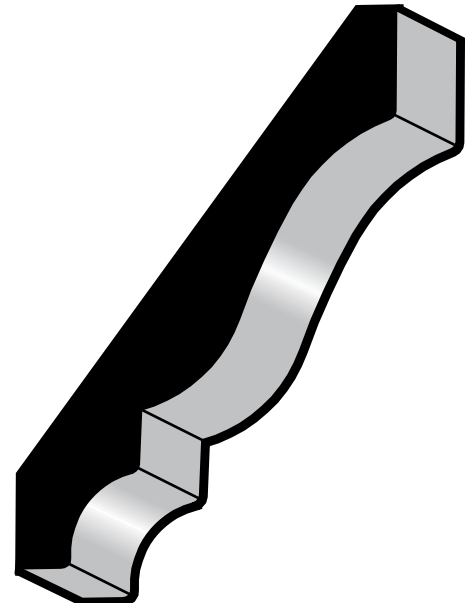

**CROWN**  **POPFP**  
49 1/2 x 3-1/2

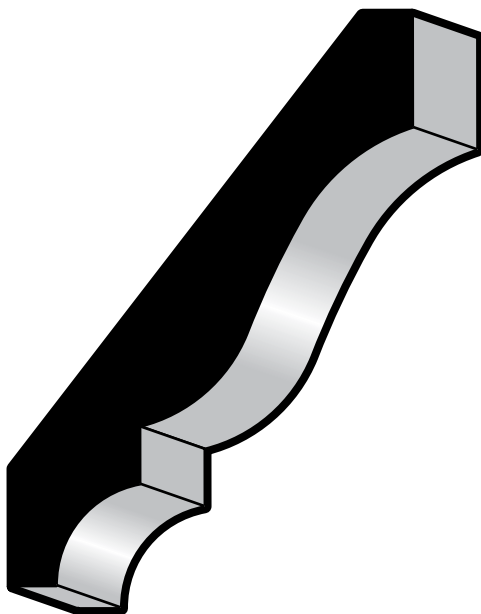

**CROWN**  
L 49 9/16 x 3-5/8 **PINE,**  
**FJPCC**  
19/32 x 3-5/8 **MDF**

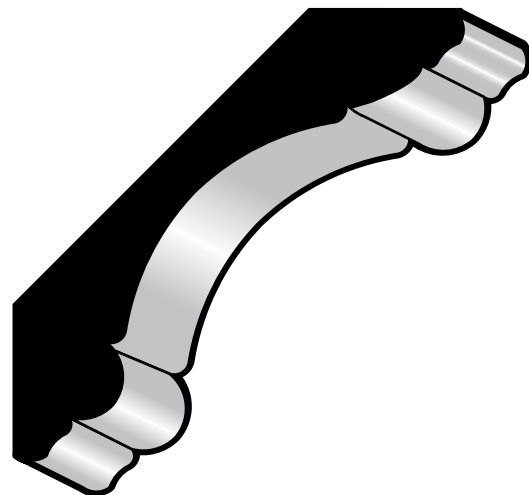

**CROWN**  
340 11/16 x 3-3/8 **MDF**

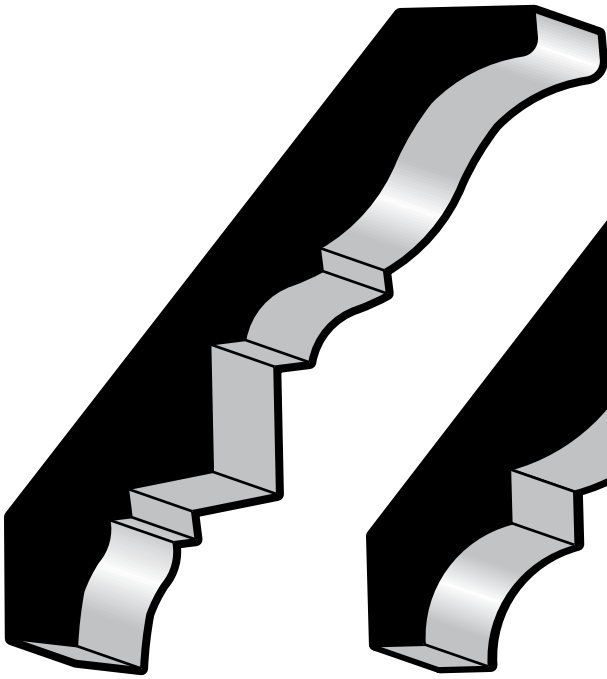

**DENTIL CROWN**  
44 11/16 x 4-1/4 **MDF**

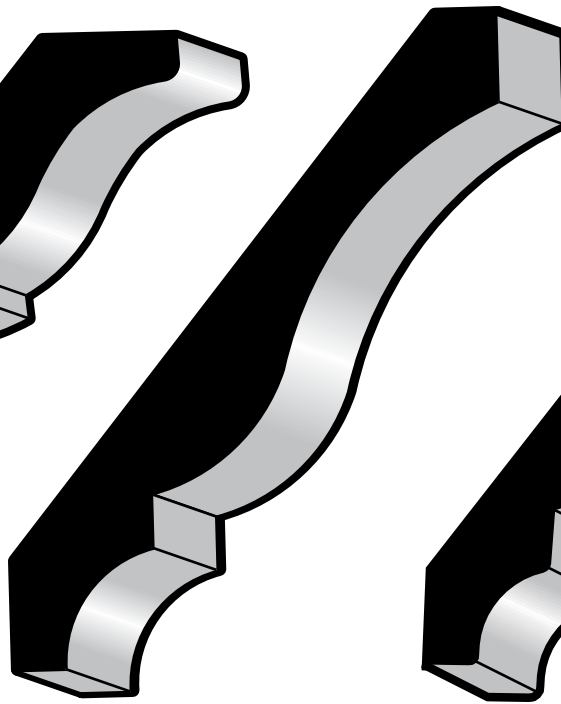

**CROWN**  
L 48 9/16 x 4-1/4 **PINE, FJPM, FJPCC**  
19/32 x 4-1/4 **MDF**  
3/4 x 4-1/4 **OAK**

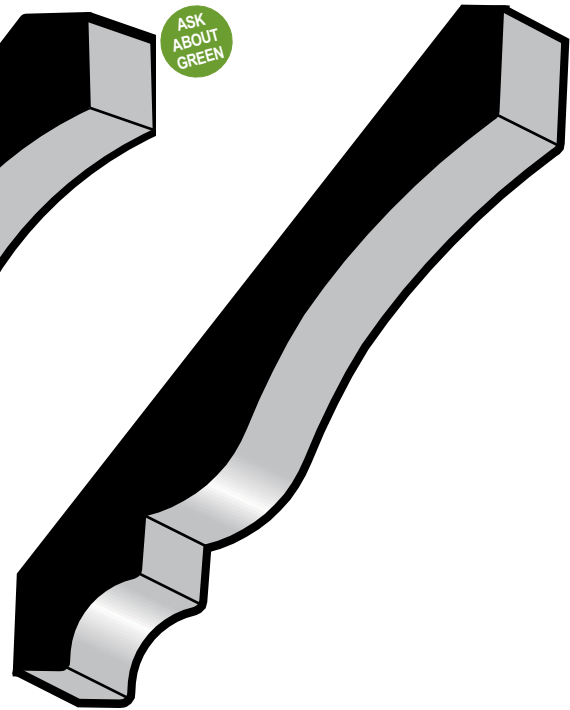

**CROWN**   
48 1/2 x 4-1/4 **POPFP**

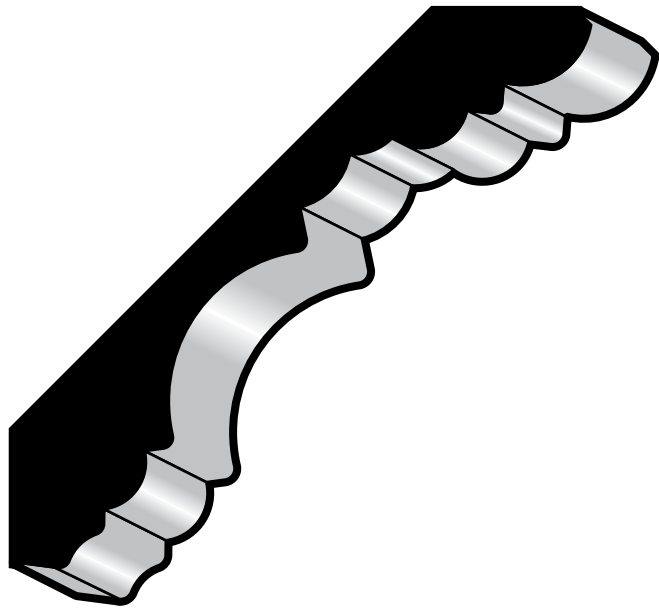

**CROWN**  
326 11/16 x 4-1/4 **MDF**

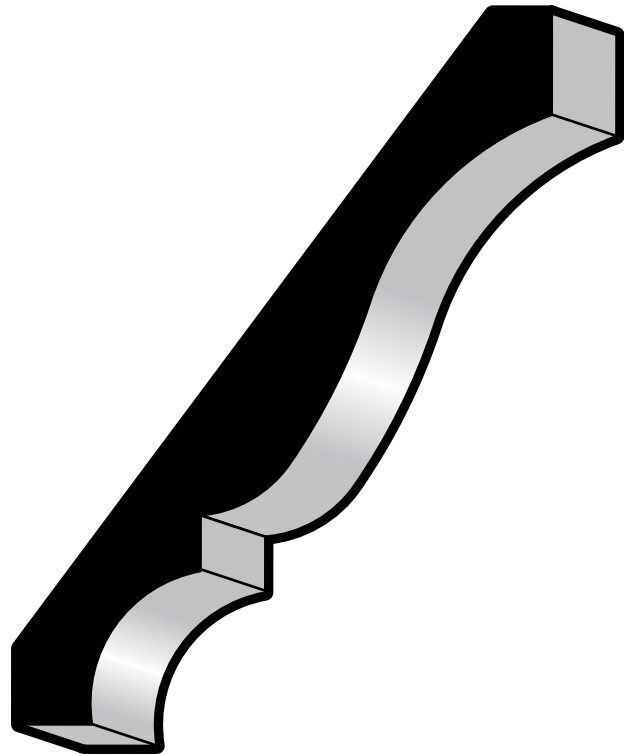

**CROWN**  
L 47 9/16 x 4-5/8 **PINE, FJPM**

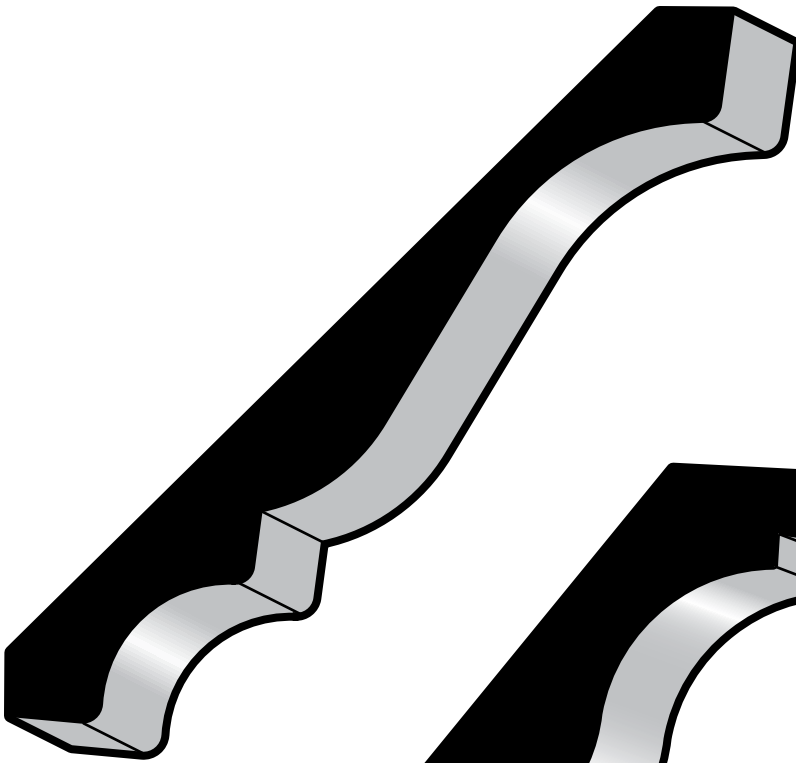

**CROWN**  
L 45 19/32 x 5-1/4 **MDF**

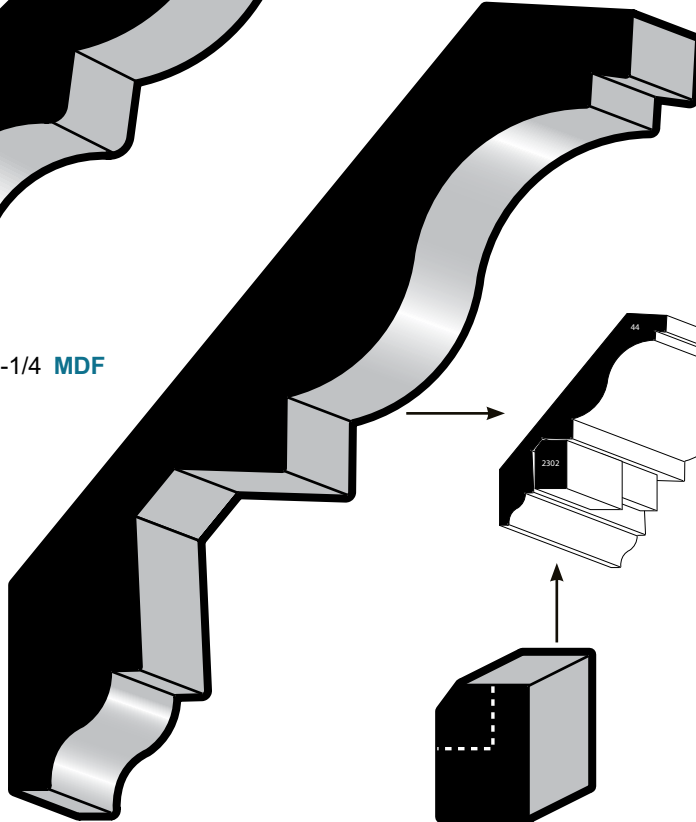

**CROWN**  
45 13/16 x 5-1/4 **OAK**

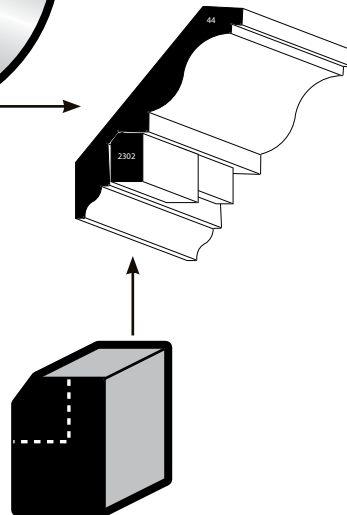

**DENTIL MOULD**  
2302 11/16 x 15/16 **OAK**

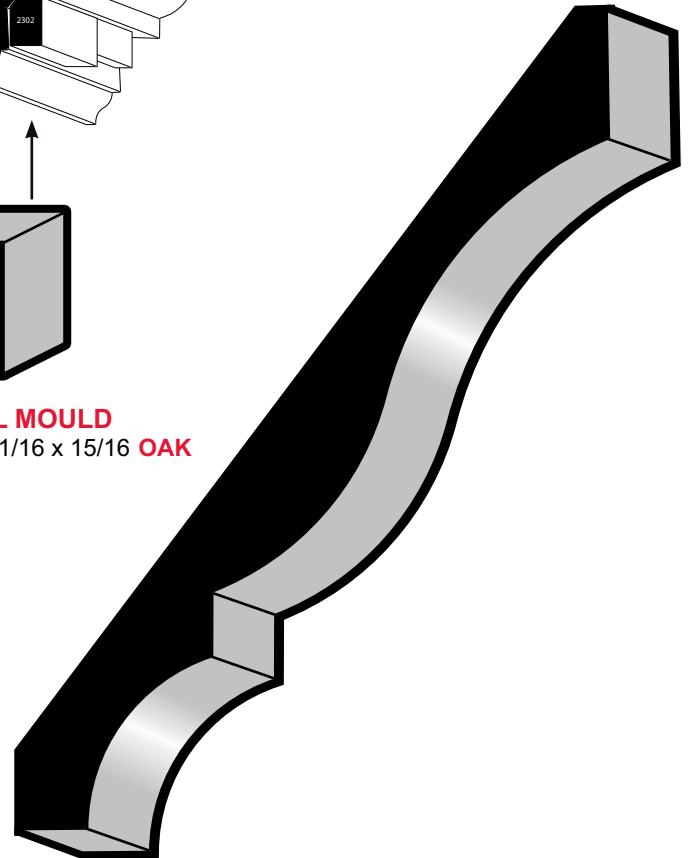

**CROWN**  
L 46 9/16 x 5-1/4 **PINE, FJPM, FJPC**  
3/4 x 5-1/4 **OAK**

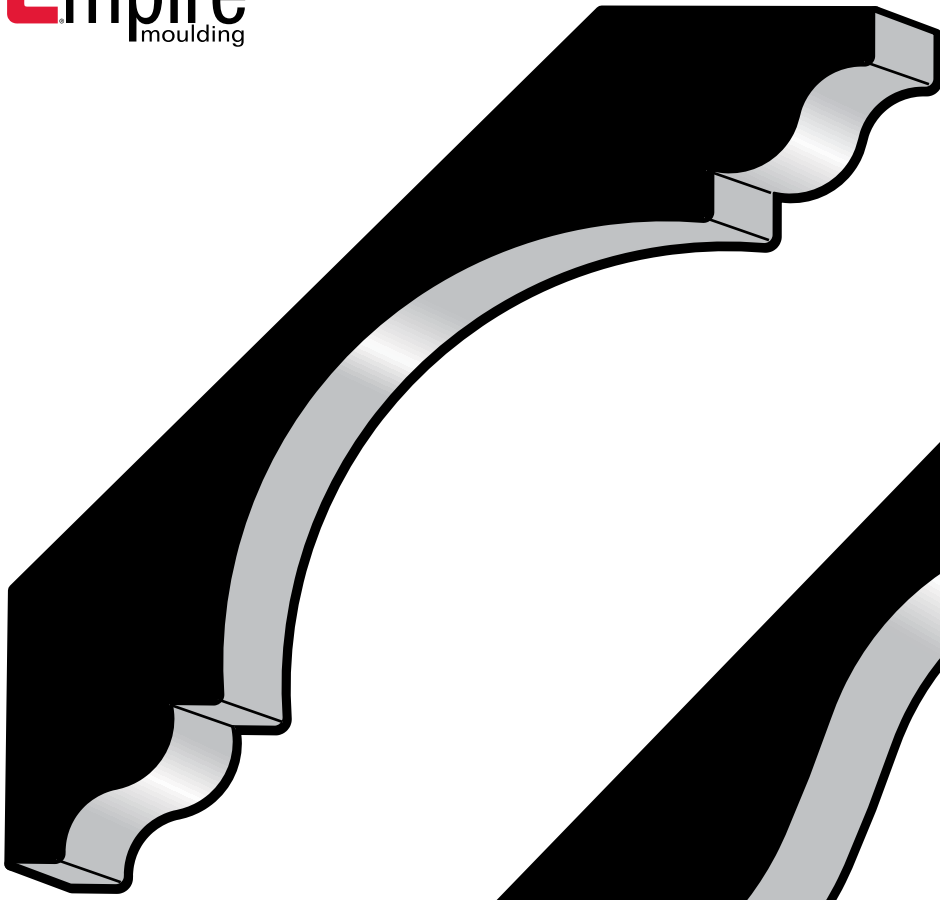

**CROWN**  
041 1-3/16 x 6-5/16 MDF

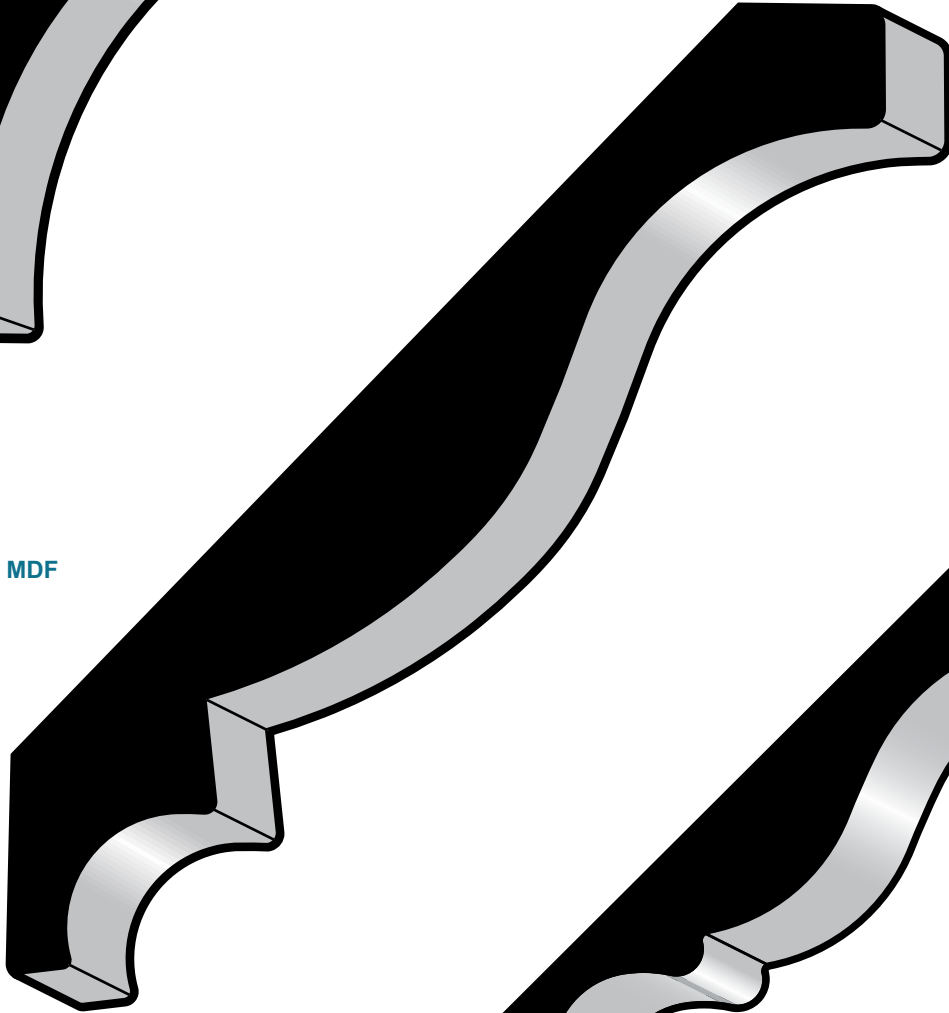

**CROWN**  
043 1 x 6-15/16 MDF

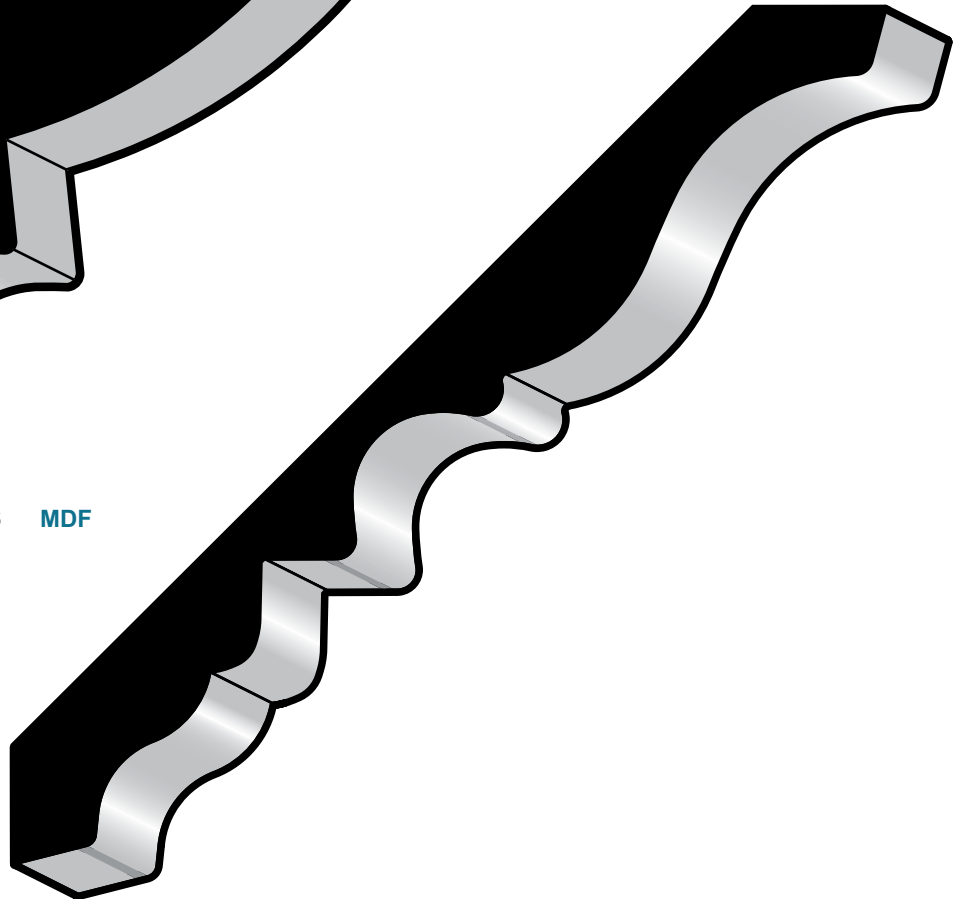

**CROWN**  
42 11/16 x 7 MDF

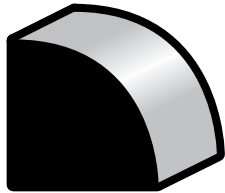

**QUARTER ROUND**

103 1-1/16 x 1-1/16 PINE  
 105 3/4 x 3/4 PINE,  
 OAK,  
 POPLR  
 106 11/16 x 11/16 PINE,  
 FJPM  
 108 1/2 x 1/2 PINE  
 110 1/4 x 1/4 PINE



**SCREEN MOULD-CLOVER**

137 3/8 x 3/4 PINE



**SCREEN MOULD**

142 1/4 x 3/4 PINE,  
 OAK



**SCREEN MOULD-BEADED**

144 1/4 x 3/4 PINE

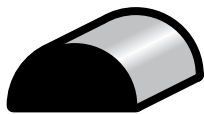

**HALF ROUND**

123 5/16 x 5/8 PINE



**EXTENDED HALF ROUND**

E 1035 1/2 x 1-3/8 POPLR



**GLASS BEAD**

147 1/2 x 9/16 PINE

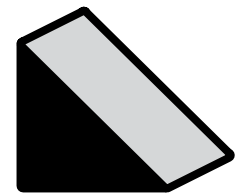

**CHAMFER**

995 3/4 x 3/4 PINE

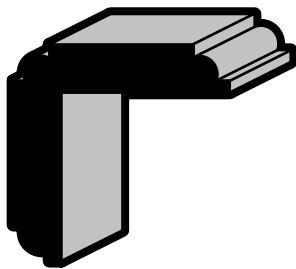

**CORNER GUARD**

202 1-1/8 x 1-1/8 PINE

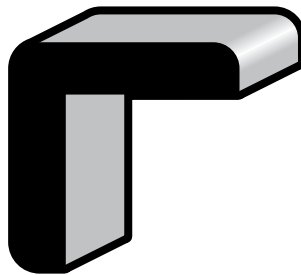

**CORNER GUARD**

204 1-5/16 x 1-5/16 PINE  
 205 1-1/16 x 1-1/16 PINE,  
 OAK  
 206 3/4 x 3/4 PINE,  
 OAK

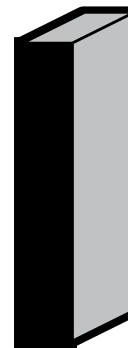

**LATTICE**

L 263 1/4 x 2-1/4 PINE  
 L 265 1/4 x 1-3/4 PINE  
 L 266 1/4 x 1-1/2 PINE  
 L 267 1/4 x 1-3/8 PINE  
 L 268 1/4 x 1-1/8 PINE

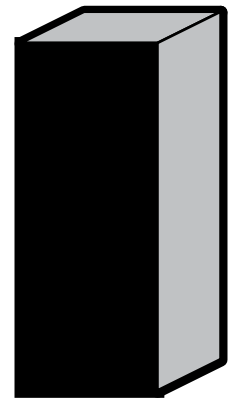

**SCREEN STOCK**

L 246 11/16 x 2-3/4 PINE,  
 FJPC  
 246 3/4 x 2-3/4 OAK,  
 POPLR  
 L 248 11/16 x 1-3/4 PINE,  
 FJPM  
 248 3/4 x 1-3/4 OAK,  
 POPLR



**SCREEN STOCK**

L 250E 11/16 x 1-1/2 MDF

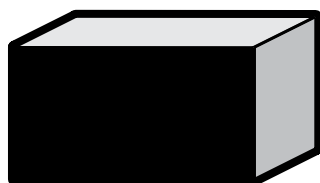

**BLIND STOP**

L 252 11/16 x 1-1/4 PINE

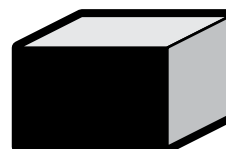

**CHECK STOP**

254 1/2 x 3/4 PINE

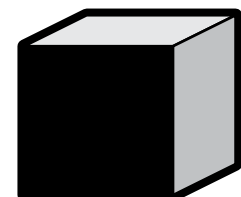

**SQUARE**

238 1-1/16 x 1-1/16 PINE  
 239 3/4 x 3/4 PINE

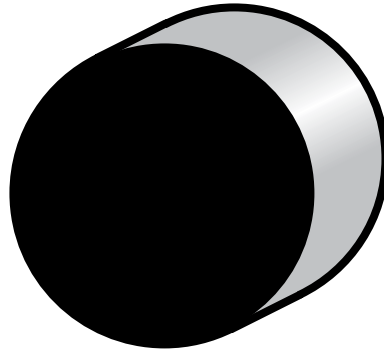

**CLOSET POLE**

- L 232 1-9/16 Full Round **DFIR**
- 1-1/2 Full Round **SPINE**
- L 233 1-1/4 Full Round **DFIR,**
- SPINE**

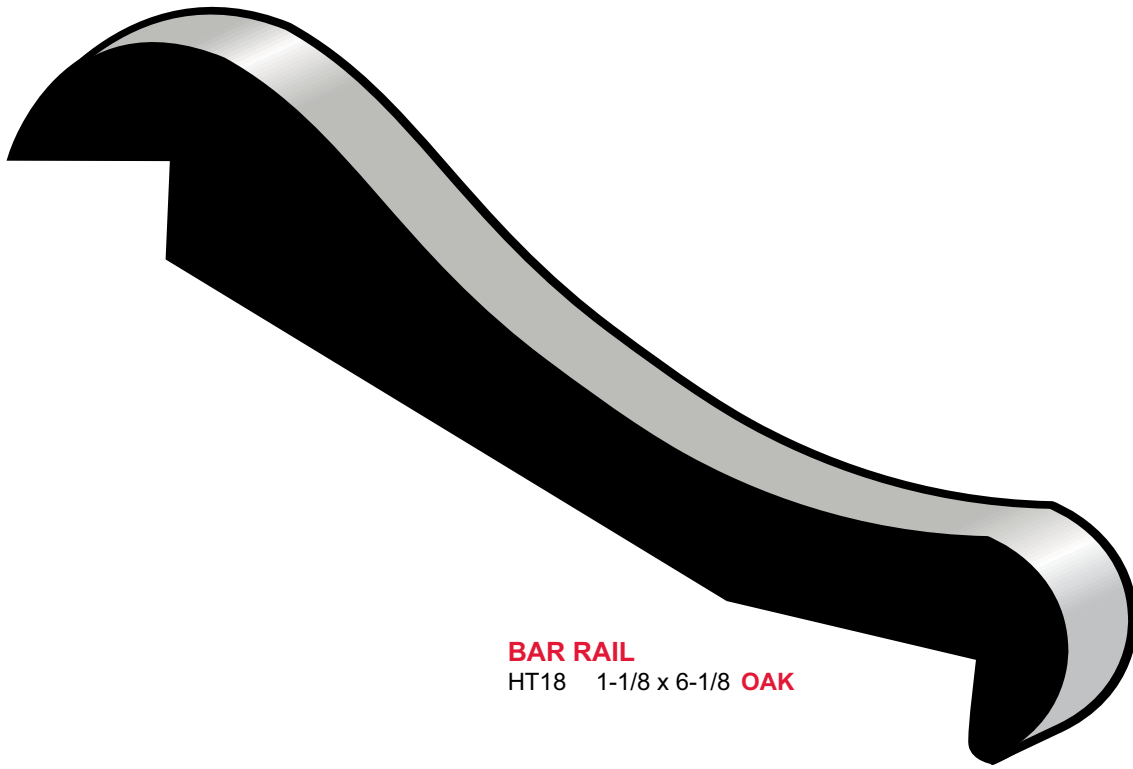

**BAR RAIL**

- HT18 1-1/8 x 6-1/8 **OAK**

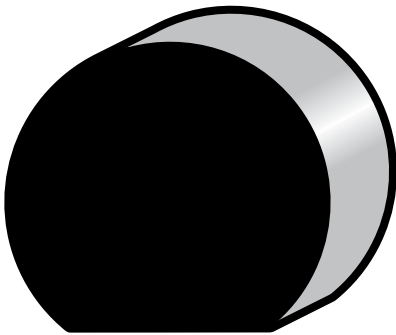

**HAND RAIL**

- 231 1-1/2 x 1-11/16 **DFIR,**
- SPINE,**
- POPLR**

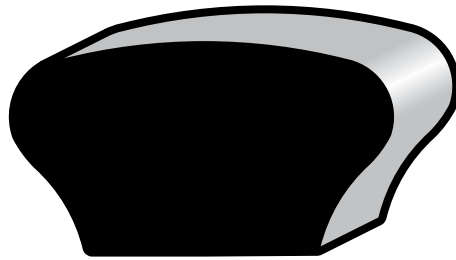

**HAND RAIL**

- L 230 1-1/4 x 2 **DFIR,**
- SPINE,**
- OAK,**
- POPLR**

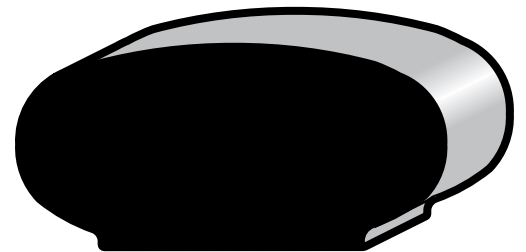

**HAND RAIL**

- 240 1-1/4 x 2-1/4 **DFIR,**
- SPINE**



### BOARDS

**1X4** 3/4 x 3-1/2  
 23/32 x 3-1/2  
 11/16 x 3-1/2  
 3/4 x 3-1/2  
 3/4 x 3-1/2  
 3/4 x 3-1/2  
 3/4 x 3-1/2  
 3/4 x 3-1/2

**PINE, FJPM, MDF, OAK, POPLR, POPFP, MAPLE**

**1X6** 3/4 x 5-1/2  
 23/32 x 5-1/2  
 11/16 x 5-1/2  
 3/4 x 5-1/2  
 3/4 x 5-1/2  
 3/4 x 5-1/2  
 3/4 x 5-1/2  
 3/4 x 5-1/2

**PINE, FJPM, MDF, OAK, POPLR, POPFP, MAPLE**

**1X8** 3/4 x 7-1/4  
 23/32 x 7-1/4  
 11/16 x 7-1/4  
 3/4 x 7-1/4  
 3/4 x 7-1/4  
 3/4 x 7-1/4  
 3/4 x 7-1/4  
 3/4 x 7-1/4

**PINE, FJPM, MDF, OAK, POPLR, POPFP, MAPLE**

**1X10** 3/4 x 9-1/4  
 11/16 x 9-1/4  
 3/4 x 9-1/4  
 3/4 x 9-1/4  
 3/4 x 9-1/4  
 3/4 x 9-1/4  
 3/4 x 9-1/4  
 3/4 x 9-1/4

**PINE, MDF, OAK, POPLR, POPFP, MAPLE, MAPV**

**1X12** 3/4 x 11-1/4  
 11/16 x 11-1/4  
 3/4 x 11-1/4  
 3/4 x 11-1/4  
 3/4 x 11-1/4  
 3/4 x 11-1/4  
 3/4 x 11-1/4

**PINE, MDF, OAK, POPLR, POPFP, MAPV**

### EASED BOARDS

**E1X4** 11/16 x 3-1/2  
**E1X6** 11/16 x 5-1/2  
 11/16 x 5-1/2  
**E1X8** 11/16 x 7-1/4  
 11/16 x 7-1/4

**MDF, FJPC, MDF, FJPC, MDF**

### FLAT JAMBS - PINE VENEER

11/16 x 4-9/16, 6-8, 81" BD	PINEV*
11/16 x 5-1/4, 6-8, 81" BD	PINEV

### FLAT JAMBS - FINGER JOINT PRIMED

11/16 x 4-5/8, 6-8, 81" BD	FJPM D
11/16 x 4-7/8, 6-8, 81" BD	FJPM D
11/16 x 4-9/16, 6-8, 81" BD	FJPM D*
11/16 x 4-9/16, 6-8, 81" BD	FJPM D - FLUTED

### FLAT JAMBS - FINGER JOINT CLAY COAT

1/16 x 4-9/16, No Dado	FJPCC
11/16 x 4-9/16, 6-8, 81" BD	FJPCC
11/16 x 6-9/16, 6-8, 81" BD	FJPCC

### FLAT JAMBS - FINGER JOINT DOUBLE PASS PRIMED

11/16 x 4-5/8, 6-8, 81-3/8" BD	FJPD P
11/16 x 4-5/8, 8-0, 97" BD	FJPD P
11/16 x 4-7/8, 8-0, 97" BD	FJPD P
11/16 x 5, 6-8, 81" BD	FJPD P
11/16 x 5, 8-0, 97" BD	FJPD P

### FLAT JAMBS - FINGER JOINT POPLAR PRIMED

11/16 x 4-5/8, 6-8, 81" BD	POPFP
11/16 x 4-5/8, 8-0, 97" BD	POPFP



### FLAT JAMBS - FINGER JOINT BARE

11/16 x 4-9/16, 6-8, 81" BD	FJBAR
-----------------------------	-------

### FLAT JAMBS - MDF

11/16 x 4-9/16, 6-8, 81" BD	MDF
-----------------------------	-----

### FLAT JAMBS - OAK VENEER

11/16 x 4-9/16, 6-8, 81" BD	OAKVN
11/16 x 4-9/16, 6-8, 81" BD	OAKOV
11/16 x 4-9/16, 6-8, 81" BD	WOAKVN

### FLAT JAMBS - BIRCH VENEER

11/16 x 4-9/16, 6-8, 81" BD	BIRVN
11/16 x 4-9/16, 6-8, 81" BD	WBIRVN

### SPLIT JAMB - 1-1/16 X 4-9/16

2-3/4 FM x 2-1/4 M, 6-8	PINE
2-3/4 FM x 2-1/4 M, 6-8	FJPM D
2-3/4 FM x 2-1/2 M, 6-8	FJPM D

\*3-0 Set Available

Profile	Below Dado	FJBAR	FJPM D	FJPCC	FJPD P	PINE	PINEV	MDF	BIRVN	WBIRVN	OAKVN	OAKOV	WOAKVN	POPFP
<b>FLAT JAMBS, 6-8</b>														
11/16 x 5	81"			X										
11/16 x 4-5/8	81"	X												X
11/16 x 4-5/8	81-3/8"			X										
11/16 x 4-7/8	81"	X												
11/16 x 5-1/4	81"					X								
11/16 x 4-9/16	81"	X	X	X		X	X	X	X	X	X	X	X	
11/16 x 4-9/16 - Fluted	81"		X											
11/16 x 4-9/16	na			X										
11/16 x 6-9/16	81"			X										
<b>FLAT JAMBS, 8-0</b>														
11/16 x 5	97"				X									
11/16 x 4-5/8	97"				X									X
11/16 x 4-7/8	97"				X									
<b>JAMB SET, 3-0 X 6-8</b>														
11/16 x 4-9/16	81"		X			X								
<b>SPLIT JAMB, 1-1/16 X 4-9/16</b>														
2-3/4 FM x 2-1/4 M, 6-8	na		X			X								
2-3/4 FM x 2-1/2 M, 6-8	na		X											

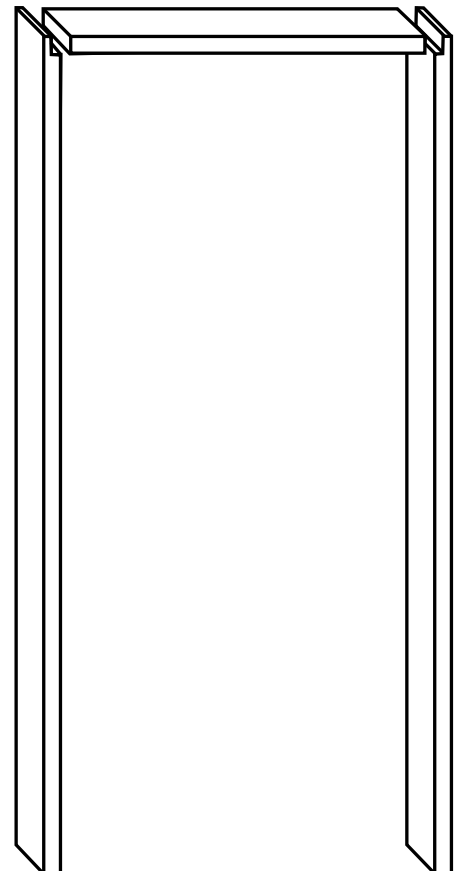

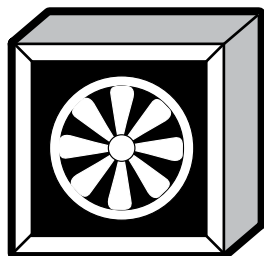

**ROSETTE - EMBOSSED**

871 1-1/16 x 3-1/2 **PINE, OAK**  
915 27/32 x 2-1/2 **PINE, OAK**

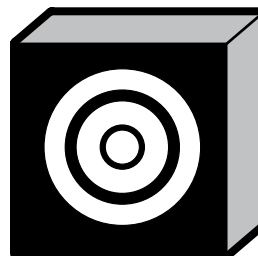

**ROSETTE - BULLSEYE**

3 7/8 x 3 **MDF**  
334 7/8 x 3-3/4 **MDF**  
P 358 1 x 3-5/8 **POPLR**  
438 1 x 4-3/8 **MDF**  
642 5/8 x 2-1/2 **PINE, OAK**  
734 27/32 x 3-1/2 **PINE, OAK**

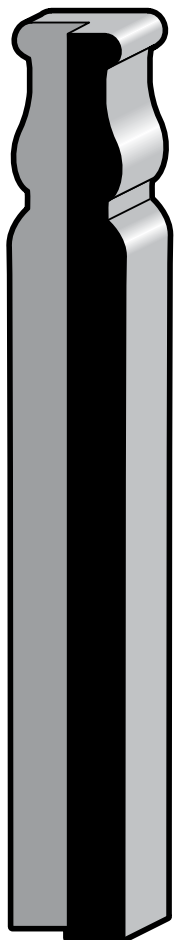

**BASE BLOCK - OUTSIDE**

9 1-1/4 x 1-1/4 x 9 **MDF**  
8920 1-1/8 x 1-1/8 x 6-3/4 **PINE**

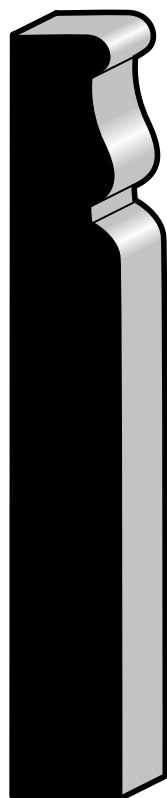

**BASE BLOCK - INSIDE**

9 7/8 x 7/8 x 9 **MDF**  
8951 7/8 x 7/8 x 6-3/4 **PINE**

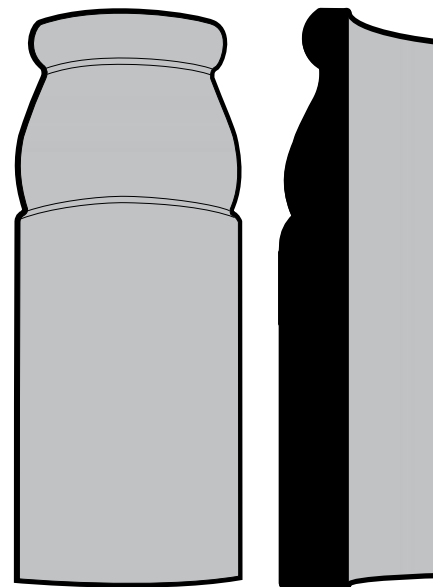

**CORNER BLOCK - RADIUS**

P 808 9/16 x 4-1/4 x 3/4 **POPLR**  
P 813 9/16 x 5-1/4 x 3/4 **POPLR**

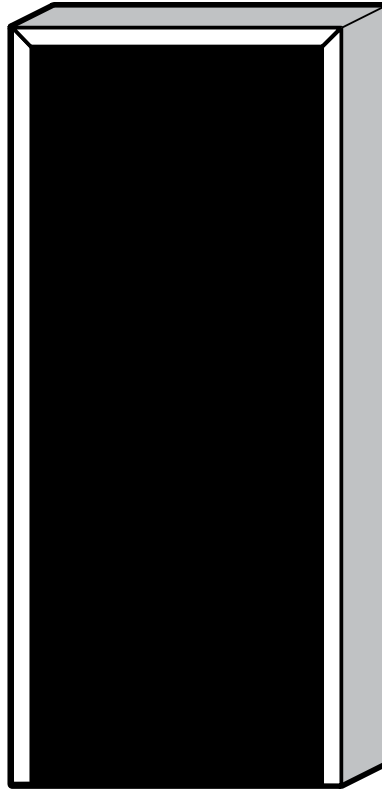

**PLINTH BLOCK - BEVELED**  
 916 27/32 x 2-1/2 x 5-3/4 **OAK**  
 917 1-1/8 x 3-1/2 x 6-1/2 **PINE, OAK**

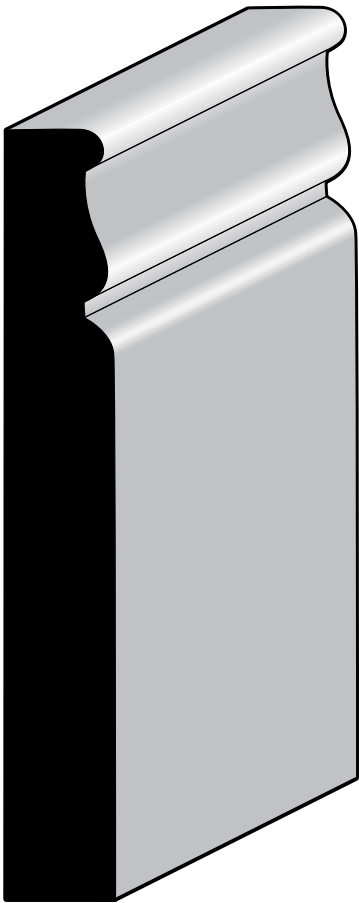

**PLINTH BLOCK**  
 334 1 x 3-3/4 x 9 **MDF**  
 438 1 x 4-3/8 x 9 **MDF**  
 742 1-1/8 x 3-1/2 x 6-1/2 **PINE, OAK**  
 887 27/32 x 2-1/2 x 5-3/4 **PINE, OAK**

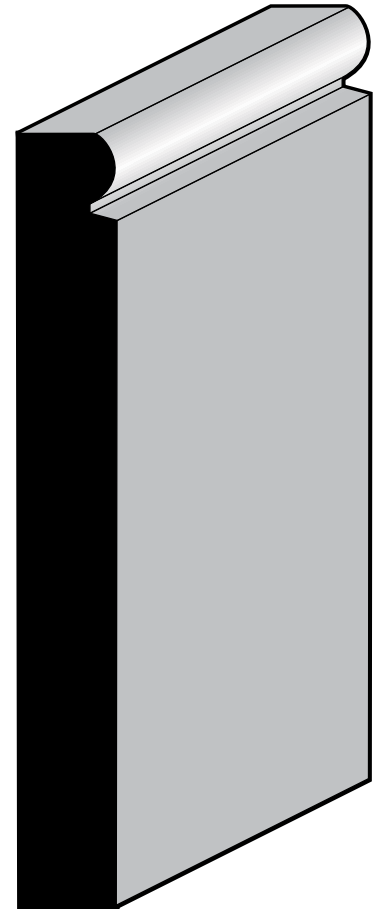

**PLINTH BLOCK**  
 P 358 1 x 3-5/8 x 8 **POPLR**

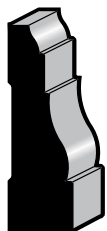

**CASING**  
366 19/32 x 2-1/4

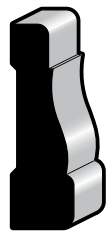

**CASING**  
356 19/32 x 2-1/4



**CASING**  
376 19/32 x 2-1/4



**CASING**  
L 473 19/32 x 2-1/4



**CASING**  
361 19/32 x 2-1/2



**CASING**  
P 380 11/16 x 2-3/4



**CASING**  
L 471 19/32 x 2-3/4



**CASING**  
4532 11/16 x 2-1/2

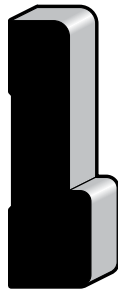

**CASING**  
685 11/16 x 2-3/4

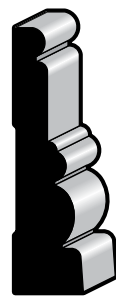

**CASING**  
4520 11/16 x 2-3/4



**CASING**  
312 19/32 x 3



**CASING**  
411 11/16 x 3



**CASING**  
L 444 19/32 x 3-1/4

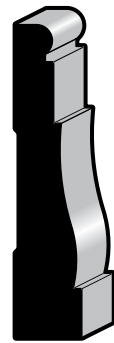

**CASING**  
445 19/32 x 3-1/4

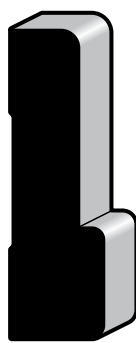

**CASING**  
682 1 x 3-1/4

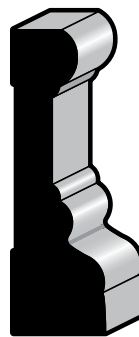

**CASING**  
PT3 1 x 3-1/4



**CASING**  
8063 11/16 x 3-1/4



**CASING**  
338 19/32 x 3-3/8



**CASING**  
374 11/16 x 3-1/2



**CASING**  
4555 11/16 x 3-1/2



**CASING**  
412 19/32 x 3-1/2

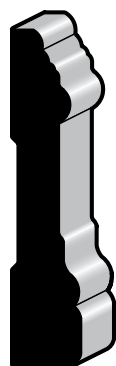

**CASING**  
535 11/16 x 3-1/2

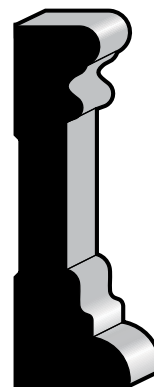

**ARCHITRAVE / CASING**  
5000 1-3/16 x 3-3/4



**CASING**  
284 19/32 x 4-1/4



**STOP**  
L 887 3/8 x 1-1/4



**STOP**  
946 3/8 x 1-3/8



**STOOL**  
1021 11/16 x 5-1/4



**BASE**  
L 433 1/2 x 3-1/4



**BASE**  
623 1/2 x 3-1/4



**BASE**  
663 1/2 x 3-1/4



**BASE**  
713 1/2 x 3-1/4



**BASE**  
410 19/32 x 4-1/4



**BASE**  
620 1/2 x 4-1/4



**BASE**  
P 808 1/2 x 4-1/4



**BASE**  
545 19/32 x 5



**BASE**  
163E 19/32 x 5-1/4



**BASE**  
B 312 19/32 x 5-1/4



**BASE**  
P 813 1/2 x 5-1/4



**BASE**  
7055 19/32 x 5-1/4



**BASE**  
512 1/2 x 5-1/2



**BASE**  
L 512 19/32 x 5-1/2



**BASE**  
8263 19/32 x 6-1/2



**BASE**  
7163 19/32 x 7-1/4



**BASE**  
207 19/32 x 7-1/4

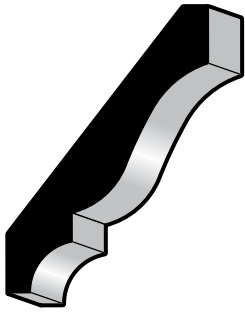

**CROWN**  
L 49 19/32 x 3-5/8

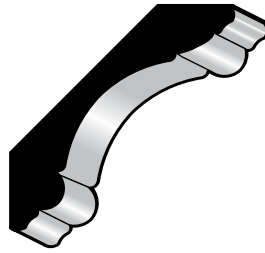

**CROWN**  
340 11/16 x 3-3/8

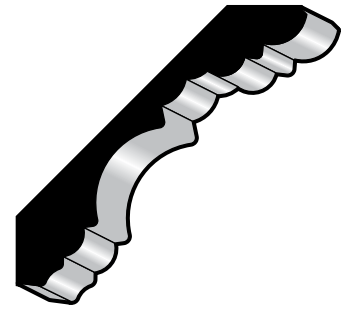

**CROWN**  
326 11/16 x 4-1/4

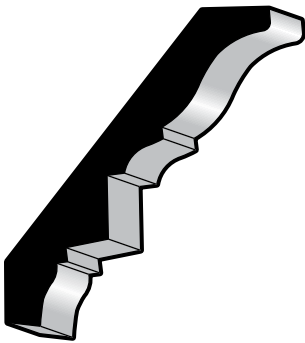

**DENTIL CROWN**  
44 11/16 x 4-1/4

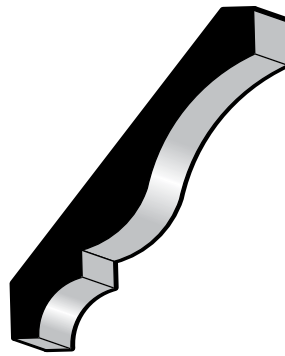

**CROWN**  
L 48 19/32 x 4-1/4

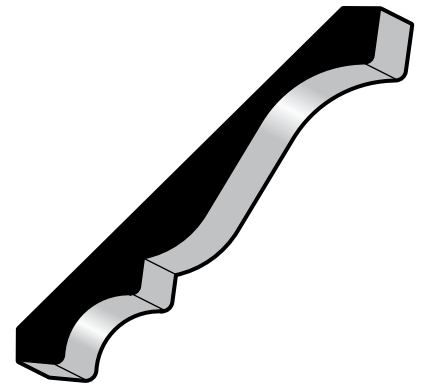

**CROWN**  
L 45 19/32 x 5-1/4

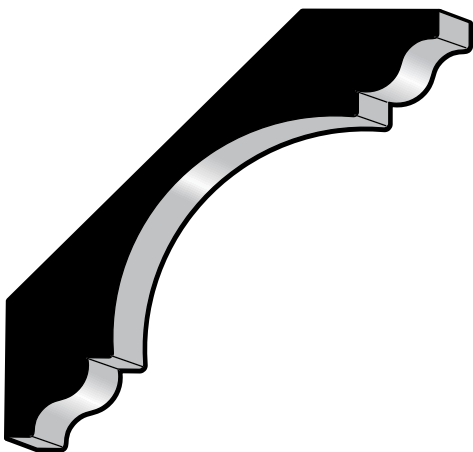

**CROWN**  
041 1-3/16 x 6-5/16

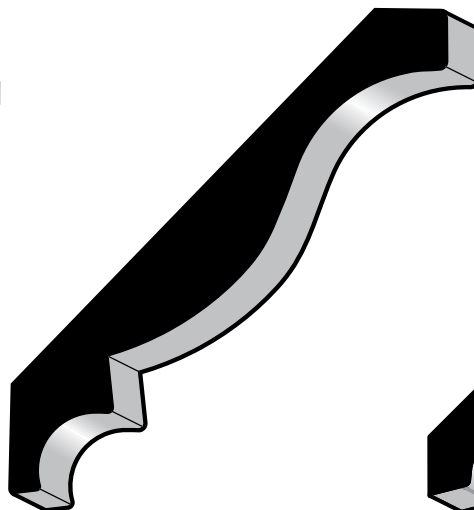

**CROWN**  
043 1 x 6-15/16

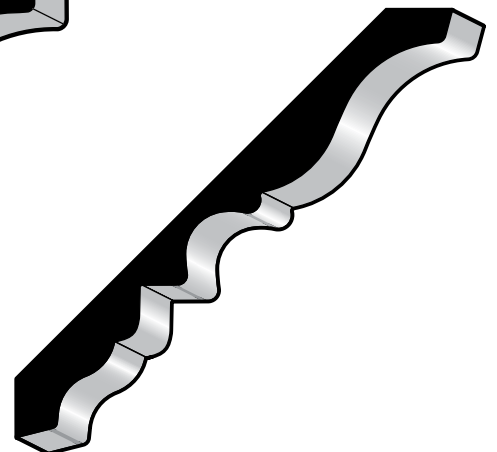

**CROWN**  
42 11/16 x 7



**SCREEN STOCK**  
L 250E 11/16 x 1-1/2



**CHAIR RAIL**  
390 19/32 x 2-5/8

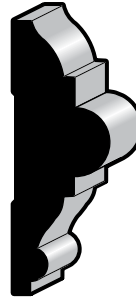

**CHAIR RAIL**  
L 300 1 x 2-7/8



**BACKER BEAD**  
956W 1/2 x 4-1/4



**WAINSCOTING CAP**  
WCAP 11/16 x 2



**WAINSCOTING**  
WC14 1/2 x 3-5/16



**WAINSCOTING**  
WC16 19/32 x 5



**WAINSCOTING**  
L WP4 19/32 x 5



**WAINSCOTING**  
SBW4 19/32 x 5-1/4



**ROSETTE  
BULLSEYE**  
3 7/8 x 3  
334 7/8 x 3-3/4  
438 1 x 4-3/8



**BASE BLOCK  
OUTSIDE**  
9 1-1/4 x 1-1/4 x 9



**BASE BLOCK  
INSIDE**  
9 7/8 x 7/8 x 9

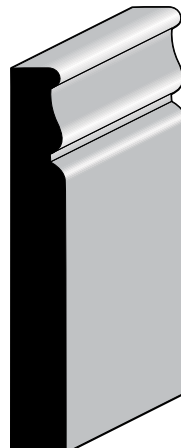

**PLINTH BLOCK**  
334 1 x 3-3/4 x 9  
438 1 x 4-3/8 x 9

**BOARDS**

1X4 11/16 x 3-1/2  
1X6 11/16 x 5-1/2  
1X8 11/16 x 7-1/4  
1X10 11/16 x 9-1/4  
1X12 11/16 x 11-1/4

**EASED EDGE BOARDS**

E1X4 11/16 x 3-1/2  
E1X6 11/16 x 5-1/2  
E1X8 11/16 x 7-1/4

**FLAT JAMBS**

11/16 x 4-9/16



## PRIME POPLAR®

Mouldings • Boards • Jambs



For a custom look without the custom price, builders and remodelers prefer Prime Poplar®.

### Consistently moulded profiles

- Architectural mouldings
- Standard mouldings
- Boards
- Jambs

### Poplar Hardwood Advantages

- stable, high quality wood
- no pitch or resin
- dent resistant
- machines well
- abundant natural resources
- competitive, consistent pricing

### Quality Finger-Jointing

- long lengths
- no telegraphing
- no joint separation

### Heavy, Uniform Primer Coat

- sanded and buffed to a sheen
- finishes with one coat of quality paint
- minimizes grain raising
- huge labor savings



*Decorator-ready architectural profiles give a custom look to any room.*



**Solid raw poplar**



**Finger-jointed paint-primed poplar**

*Poplar products so thoroughly primed, sanded and buffed, they could be mistaken for finish-painted.*



**CASING**  
102 5/8 x 2-1/4

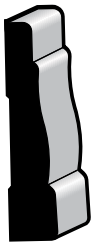

**CASING**  
207 1/2 x 2-1/4



**CASING**  
252 5/8 x 2-1/2



**CASING**  
193 5/8 x 3-1/4



**CASING**  
254 1/2 x 3-1/2



**CASING**  
719 11/16 x 3-1/2

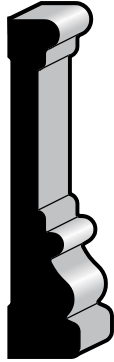

**CASING**  
722 3/4 x 3-1/2



**CASING**  
1942 11/16 x 3-1/2



**STOP**  
402 3/8 x 1-1/4



**STOP**  
403 3/8 x 1-1/4



**BASE**  
312 3/8 x 3



**BASE**  
322 3/8 x 3-1/4



**BASE**  
353 1/2 x 4-1/4



**BASE**  
355 3/8 x 4-1/4



**BASE**  
760 7/16 x 4-1/4



**SHOE**  
21 7/16 x 3/4

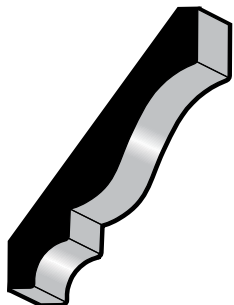

**CROWN**  
49 1/2 x 3-1/2

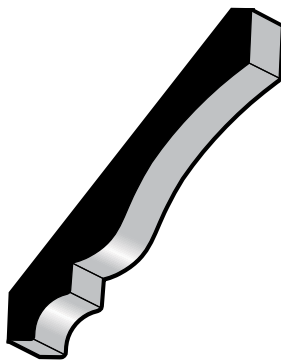

**CROWN**  
48 1/2 x 4-1/4

**BOARDS**

- 1X4 3/4 x 3-1/2
- 1X6 3/4 x 5-1/2
- 1X8 3/4 x 7-1/4
- 1X10 3/4 x 9-1/4
- 1X12 3/4 x 11-1/4

**FLAT JAMBS**

- 11/16 x 4-5/8, 6-8, 81" BD
- 11/16 x 4-5/8, 8-0, 97" BD

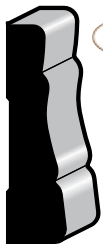

**CASING**  
102 5/8 x 2-1/4  
POPFP

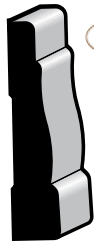

**CASING**  
207 1/2 x 2-1/4  
POPFP

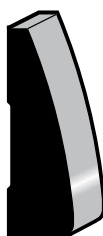

**CASING**  
316 5/8 x 2-1/4  
OAK

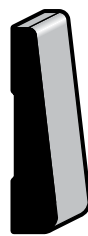

**CASING**  
L 324 1/2 x 2-1/4  
OAK

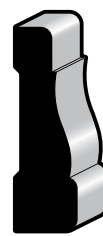

**CASING**  
356 5/8 x 2-1/4  
OAK, POPLR



**CASING**  
L 356 1/2 x 2-1/4  
OAK, MAPLE



**CASING**  
V 357 11/16 x 2-1/4  
OAKVN

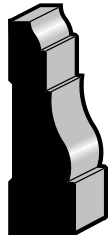

**CASING**  
366 5/8 x 2-1/4  
OAK, POPLR

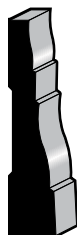

**CASING**  
L 366 1/2 x 2-1/4  
OAK



**CASING**  
L 473 1/2 x 2-1/4  
OAK, POPLR



**CASING**  
8900 3/8 x 2-1/4  
OAK



**CASING**  
252 5/8 x 2-1/2  
POPFP

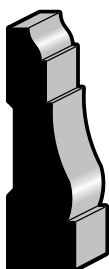

**CASING**  
361 9/16 x 2-1/2  
OAK



**CASING**  
475 9/16 x 2-1/2  
OAK



**CASING**  
4530 3/4 x 2-1/2  
OAK



**CASING**  
P 380 11/16 x 2-3/4  
POPLR



**CASING**  
474 11/16 x 2-3/4  
OAK, POPLR



**CASING**  
8901 1/2 x 3  
OAK



**CASING**  
40 9/16 x 3-1/4  
OAK



**CASING**  
195 11/16 x 3-1/4  
OAK



**CASING**  
193 5/8 x 3-1/4  
POPFP



**CASING**  
L 444 11/16 x 3-1/4  
POPLR  
3/4 x 3-1/4  
OAK, MAPLE



**CASING**  
254 1/2 x 3-1/2  
POPFP

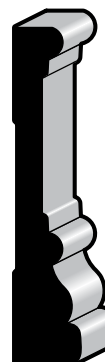

**CASING**  
P 450 11/16 x 3-1/2  
POPLR

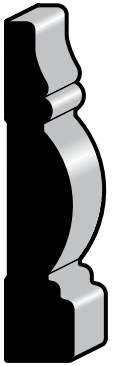

**CASING**  
374 3/4 x 3-1/2  
**OAK**



**CASING**  
719 11/16 x 3-1/2  
**POPFP**

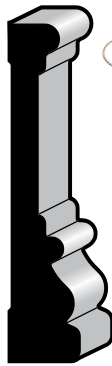

**CASING**  
722 3/4 x 3-1/2  
**POPFP**



**CASING**  
1942 11/16 x 3-1/2  
**POPFP**



**MULLION**  
960 3/16 x 4  
**OAK**



**MULLION**  
962 1/4 x 2-1/4  
**OAK**



**MULLION**  
L 982 1/2 x 2  
**OAK**



**STOP**  
402 3/8 x 1-1/4  
**POPFP**



**STOP**  
403 3/8 x 1-1/4  
**POPFP**



**STOP**  
L 887 3/8 x 1-1/4  
**OAK, POPLR**



**STOP**  
947 3/8 x 1-1/4  
**OAK, POPLR, MAPLE**



**STOP**  
846 7/16 x 1-3/8  
**OAK**



**STOP**  
L 886 3/8 x 1-3/8  
**OAK**



**STOP**  
916 3/8 x 1-3/8  
**OAK**



**STOP**  
936 7/16 x 1-3/8  
**OAK, POPLR**



**STOP - BI FOLD**  
B FOLD 3/4 x 1-5/8  
**OAK**



**SHOE**  
21 7/16 x 3/4  
**POPFP**  
126 1/2 x 3/4  
**OAK, POPLR, MAPLE**



**CLOVER LEAF SHOE**  
34 3/4 x 3/4  
**OAK**



**BASE CAP**  
172 5/8 x 3/4  
**OAK**



**BASE CAP**  
163 11/16 x 1-3/8  
**POPLR**



**BASE**  
L 634 3/8 x 2-3/4  
**OAK, MAPLE**



**BASE**  
L 724 3/8 x 2-3/4  
**OAK**



**BASE**  
L 635 3/8 x 3  
**OAK**



**BASE**  
312 3/8 x 3  
**POPFP**



**BASE**  
L 433 3/8 x 3  
**OAK, POPLR**



**BASE**  
634 1/2 x 3  
**OAK**

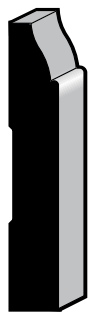

**BASE**  
H 634 1/2 x 3  
OAK, POPLR



**BASE**  
724 1/2 x 3  
OAK



**BASE**  
322 3/8 x 3-1/4  
POPPF



**BASE**  
623 9/16 x 3-1/4  
OAKVN



**BASE**  
L 623 3/8 x 3-1/4  
POPLR



**BASE**  
633 1/2 x 3-1/4  
OAK



**BASE**  
H 633 1/2 x 3-1/4  
OAK, POPLR



**BASE**  
723 1/2 x 3-1/4  
OAK



**BASE**  
P 805 1/2 x 3-1/4  
POPLR



**BASE**  
353 1/2 x 4-1/4  
POPPF



**BASE**  
355 3/8 x 4-1/4  
POPPF



**BASE**  
L 620 1/2 x 4-1/4  
OAK, POPLR



**BASE**  
675 1/2 x 4-1/4  
OAK



**BASE**  
P 808 1/2 x 4-1/4  
OAK, POPLR, MAPLE



**BASE**  
760 7/16 x 4-1/4  
POPPF



**BASE**  
674 1/2 x 5-1/4  
OAK



**BASE**  
695 1/2 x 5-1/4  
OAK



**CHAIR RAIL**  
390 5/8 x 2-5/8  
OAK, POPLR



**CAP**  
L 294 11/16 x 1-1/16  
OAK



**PLY CAP**  
292 1/2 x 1-1/16  
OAK



**BACK BAND**  
E 282 1-7/8 x 1-1/8  
POPLR

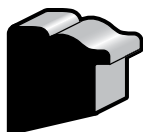

**BACK BAND**  
283 1-1/16 x 1-1/8  
OAK, POPLR



**PANEL MOULD**  
262 11/16 x 1-9/16  
OAK



**PANEL MOULD**  
263 11/16 x 1-9/16  
OAK



**PANEL MOULD**  
190 1 x 2  
POPLR



**LIP MOULD**  
158 3/4 x 1-5/8  
OAK



**DENTIL MOULD**  
2302 11/16 x 15/16  
**OAK**



**CROWN**  
L 68 5/8 x 1-5/8  
**OAK**

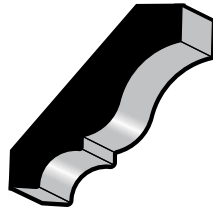

**CROWN**  
L 54 1/2 x 2-1/4  
**OAK**

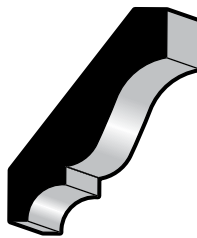

**CROWN**  
52 1/2 x 2-3/4  
**OAK**

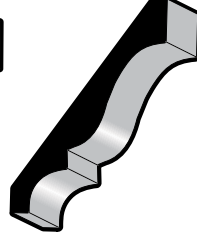

**CROWN**  
L 52 3/8 x 2-3/4  
**OAK**

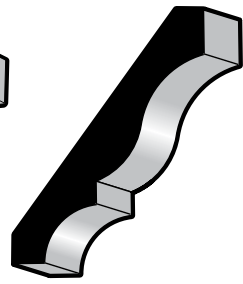

**CROWN**  
51 1/2 x 3-1/4  
**OAK**



**COVE**  
93 3/4 x 3/4  
**OAK, MAPLE**  
100 11/16 x 11/16  
**POPLR**

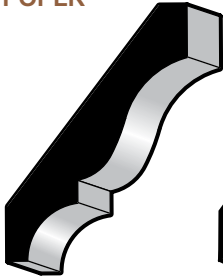

**CROWN**  
L 51 9/16 x 3-1/4  
**POPLR**  
1/2 x 3-1/4

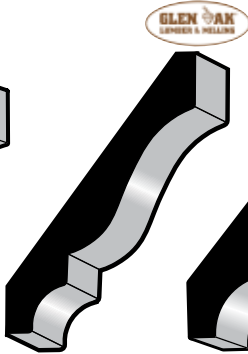

**CROWN**  
49 1/2 x 3-1/2  
**POPFP**

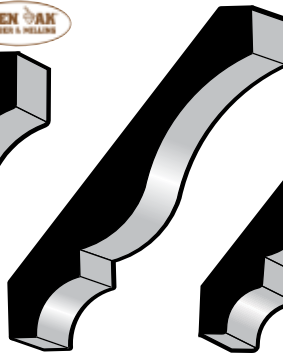

**CROWN**  
L 48 3/4 x 4-1/4  
**OAK**

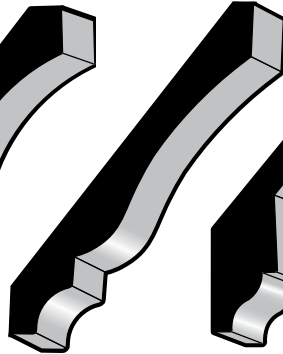

**CROWN**  
48 1/2 x 4-1/4  
**POPFP**

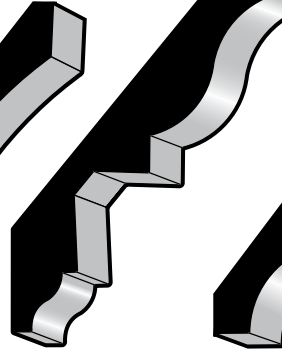

**CROWN**  
45 13/16 x 5-1/4  
**OAK**

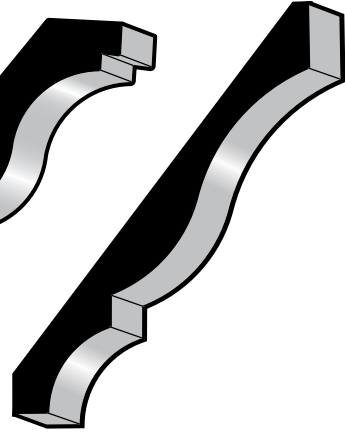

**CROWN**  
L 46 3/4 x 5-1/4  
**OAK**

**MAPLE**  
V 51 5/8 x 3-1/4  
**OAKVN**



**SCREEN MOULD**  
142 1/4 x 3/4  
**OAK**



**QUARTER ROUND**  
105 3/4 x 3/4  
**OAK, POPLR**



**EXTENSION HALF ROUND**  
E 1035 1/2 x 1-3/8  
**POPLR**

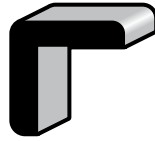

**CORNER GUARD**  
205 1-1/16 x 1-1/16  
**OAK**  
206 3/4 x 3/4  
**OAK**

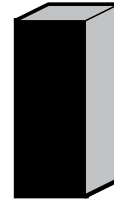

**SCREEN STOCK**  
246 3/4 x 2-3/4  
**OAK, POPLR**  
248 3/4 x 1-3/4  
**OAK, POPLR**

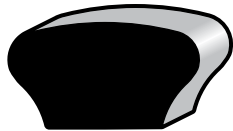

**HAND RAIL**  
L 230 1-1/4 x 2  
**OAK, POPLR**

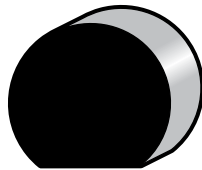

**HAND RAIL**  
231 1-1/2 x 1-11/16  
**POPLR**

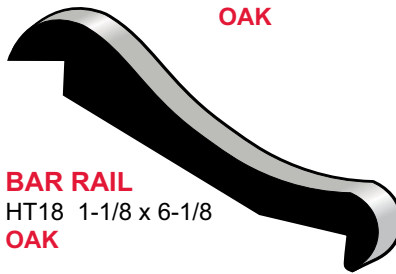

**BAR RAIL**  
HT18 1-1/8 x 6-1/8  
**OAK**

JAMBS						
Profile	BIRVN	WBIRVN	OAKVN	OAKOV	WOAKVN	POPFP
11/16 x 4-9/16, 81" BD	X		X	X	X	
11/16 x 4-5/8, 81" BD						X
11/16 x 4-5/8, 97" BD						X















BOARDS							
Profile	MAPLE	MAPV	OAK	OAKVN	POPLR	POPFP	POP - FJ / EG
1 x 4	X		X		X	X	
1 x 6	X		X		X	X	
1 x 8	X		X		X	X	
1 x 10	X	X	X	X	X	X	X
1 x 12		X	X	X	X	X	X













































BLOCKS		
Profile	OAK	POPLR
<b>ROSETTE</b>		
P 358		X
642	X	
734	X	
871	X	
915	X	
<b>BASE BLOCKS</b>		
P 808		X
P 813		X



















BLOCKS		
Profile	OAK	POPLR
<b>PLINTH BLOCKS</b>		
P 358		X
742	X	
887	X	
916	X	
917	X	



















# Quick Reference















Profile	Page #	DFIR	FJBAR	FJPMID	FJPC	FJDP	PINE	SPINE	MDF	MAPLE	OAK	OAKVN	POPLR	POPEP
 21	25													X
 34	25						X				X			
 40	10										X			
 041	33								X					
 42	33								X					
 043	33								X					
 44	31								X					
 45	32										X			
 L 45	32								X					
 L 46	32			X	X		X				X			
 L 47	31			X			X							
 48	31													X
 L 48	31			X	X		X		X		X			













Profile	Page #	DFIR	FJBAR	FJPMID	FJPC	FJDP	PINE	SPINE	MDF	MAPLE	OAK	OAKVN	POPLR	POPEP
 49	30													X
 L 49	30				X		X		X					
 51	30										X			
 L 51 / V 51	30			X	X	X	X			X		X	X	
 52	29						X				X			
 L 52	29										X			
 54	29			X			X							
 L 54	29										X			
 68 / L 68	29						X				X			
 74	29			X			X							
 75	29						X							
 84	29						X							
 85	29						X							
 86	29						X							
 93	29						X		X	X				
 L 94	29						X							
 100	29						X						X	
 101	29						X							
 102	6													X









Profile	Page #	DFIR	FJBAR	FJPMID	FJPC	FJDP	PINE	SPINE	MDF	MAPLE	OAK	OAKVN	POPLR	POPEP
 103	34						X							
 105	34						X				X		X	
 106	34			X			X							
 108	34						X							
 110	34						X							
 123	34						X							
 126	25			X			X		X	X			X	
 129	25			X			X							
 137	34						X							
 142	34						X			X				
 144	34						X							
 147	34						X							
 158	27									X				
 163	25												X	
 163E	22							X						
 166	25			X			X							
 L 167	25						X							
 172	25									X				
 L 177	16		X											
 180	16		X	X										
 183	26						X							
 182	26			X										
 185	26						X							

Profile	Page #	DFIR	FJBAR	FJPMID	FJPC	FJDP	PINE	SPINE	MDF	MAPLE	OAK	OAKVN	POPLR	POPEP
 190	26												X	
 193	10													X
 195	10										X			
 L 197	16			X			X							
 202	34						X							
 204	34						X							
 205	34						X				X			
 206	34						X				X			
 207	6													X
 207	24								X					
 E 208	16			X										
 L 210	16			X			X							
 L 230	35	X						X			X		X	
 231	35	X						X					X	
 L 232	35	X						X						
 L 233	35	X						X						
 238	34						X							
 239	34						X							



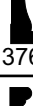

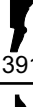

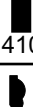
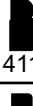





Profile	Page #	DFIR	FJBAR	FJPMID	FJPC	FJDP	PINE	SPINE	MDF	MAPLE	OAK	OAKVN	POPLR	POPEP
 240	35	X						X						
 246	34										X		X	
 L 246	34				X		X							
 248	34										X		X	
 L 248	34		X				X							
 L 250E	34							X						
 252	8													X
 L 252	34						X							
 254	34						X							
 254	12													X
 262	26										X			
 263	26										X			
 L 263	34						X							
 L 265	34						X							
 L 266	34						X							
 L 267	34						X							
 L 268	34						X							
 280	26						X							
 281	26						X							









Profile	Page #	DFIR	FJBAR	FJPMID	FJPC	FJDP	PINE	SPINE	MDF	MAPLE	OAK	OAKVN	POPLR	POPEP
 E 282	26												X	
 283	26										X		X	
 284	13								X					
 292	27						X				X			
 L 294	27										X			
 L 300	27								X					
 312	18													X
 312	10								X					
 B 312	22								X					
 316	6		X				X				X			
 321	6						X							
 322	19													X
 324	6		X				X							
 L 324	6						X				X			









Profile	Page #	DFIR	FJBAR	FJPMID	FJPC	FJDP	PINE	SPINE	MDF	MAPLE	OAK	OAKVN	POPLR	POPP
 326	31								X					
 327	6			X			X							
 338	12								X					
 340	30								X					
 351	8			X			X							
 353	21													X
 355	21													X
 356	6			X	X		X		X		X			
 L 356	6									X	X			
 V 357	7											X		
 361	8			X	X		X		X		X			
 L 361	12			X			X							
 366	7			X	X		X		X		X			



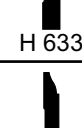
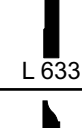

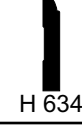
Profile	Page #	DFIR	FJBAR	FJPMID	FJPC	FJDP	PINE	SPINE	MDF	MAPLE	OAK	OAKVN	POPLR	POPP
 L 366	7										X			
 L 366	10			X	X									
 L 367	11						X							
 374	12				X				X		X			
 376	7			X			X		X					
 P 380	9			X	X		X		X				X	
 390	27			X	X		X		X		X		X	
 391	27						X							
 402	15													X
 403	15													X
 410	21								X					
 411	10								X					
 412	12								X					

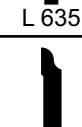
# Quick Reference



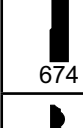

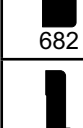
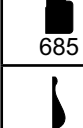

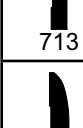
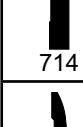
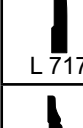





Profile	Page #	DFIR	FJBAR	FJPMID	FJPC	FJDP	PINE	SPINE	MDF	MAPLE	OAK	OAKVN	POPLR	POPEP
 432	12					X								
 433	19		X											
 L 433	19		X				X		X		X		X	
 442	7			X										
 L 444	11			X	X		X		X	X	X		X	
 445	11			X	X		X		X					
 P 450	12			X	X								X	
 L 471	9								X					
 473	7		X				X							
 L 473	7		X						X		X		X	
 474	9				X						X		X	
 475	8										X			
 493	14						X							









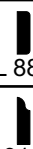
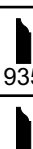

Profile	Page #	DFIR	FJBAR	FJPMID	FJPC	FJDP	PINE	SPINE	MDF	MAPLE	OAK	OAKVN	POPLR	POPEP
 512	24								X					
 L 512	24								X					
 535	12								X					
 545	22								X					
 618	22				X		X							
 620	21			X	X		X		X					
 L 620	21										X		X	
 623	19			X	X		X		X			X		
 L 623	19												X	













Profile	Page #	DFIR	FJBAR	FJPMID	FJPC	FJDP	PINE	SPINE	MDF	MAPLE	OAK	OAKVN	POPLR	POPEP
 L 627	18						X							
 633	20										X			
 H 633	20										X		X	
 L 633	20			X	X		X							
 634	18										X			
 H 634	18										X		X	
 L 634	18			X	X		X		X	X				
 L 635	19										X			
 658	22			X										
 663	20			X	X		X		X					
 664	19						X							













Profile	Page #	DFIR	FJBAR	FJPMID	FJPC	FJDP	PINE	SPINE	MDF	MAPLE	OAK	OAKVN	POPLR	POPEP
 674	23				X						X			
 675	21										X			
 682	11								X					
 685	9								X					
 695	23										X			
 713	20			X			X		X					
 714	19						X							
 L 717	18						X							
 719	13													X
 722	13													X
 723	20										X			





# Quick Reference

Profile	Page #	DFIR	FJBAR	FJPMID	FJPCC	FJDP	PINE	SPINE	MDF	MAPLE	OAK	OAKVN	POPLR	POPEP
 L 723	20						X							
 724	19										X			
 L 724	18			X			X				X			
 760	21													X
 P 805	20			X	X									X
 P 808	21			X	X		X		X	X	X			X
 P 813	23			X	X		X		X					
 845	15						X							
 846	15						X				X			
 856	15			X			X							
 857	15						X							
 L 876	15			X										
878	15			X										
L 886	15										X			

Profile	Page #	DFIR	FJBAR	FJPMID	FJPCC	FJDP	PINE	SPINE	MDF	MAPLE	OAK	OAKVN	POPLR	POPEP
 L 887	15						X		X		X		X	
 916	15										X			
 935	15						X							
 936	15				X	X	X				X		X	
 946	15						X		X					
 947	15			X		X	X			X	X		X	
 956W	27								X					
 960	14										X			
 962	14										X			
 972	14						X							
 L 973	14						X							
 982	14						X							
L 982	14										X			
L 983	14						X							
995	34						X							
1021	17						X		X					
E 1035	17 34												X	
1153	17						X							
1155	17						X							

Profile	Page #	DFIR	FJBAR	FJPMID	FJPC	FJDP	PINE	SPINE	MDF	MAPLE	OAK	OAKVN	POPLR	POPPP
 1305	16						X							
 1942	13													X
 2302	32										X			
 4520	9								X					
 4530	8										X			
 4532	8								X					
 4555	13								X					
 5000	13								X					
 7055	23								X					
 7163	24								X					
 7705	9			X										
 8063	11								X					

Profile	Page #	DFIR	FJBAR	FJPMID	FJPC	FJDP	PINE	SPINE	MDF	MAPLE	OAK	OAKVN	POPLR	POPPP
 8263	24								X					
 8296	11						X							
 8900	7										X			
 8901	10										X			
 B FOLD	15						X				X			
 FLTD	11		X											
 L FLTD	10						X							
 HT18	35										X			
 N/L	17						X							
 PT3	11								X					
 L PT3	13				X									
 REV	11						X							

Profile	Page #	DFIR	FJBAR	FJPMDF	FJPCC	FJDP	PINE	SPINE	MDF	MAPLE	OAK	OAKVN	POPLR	POPP
 SBW4	28								X					
 WCAP	26								X					
 WC14	28								X					
 WC16	28								X					
 L WP4	28								X					

BOARDS													
Profile	Page #	FJPMDF	FJPCC	PINE	MDF	MAPLE	MAPV	OAK	OAKVN	POPLR	POPP	POP - F/J/EG	
1 x 4	36	X		X	X	X		X		X	X		
1 x 6	36	X		X	X	X		X		X	X		
1 x 8	36	X		X	X	X		X		X	X		
1 x 10	36			X	X	X	X	X	X	X	X	X	
1 x 12	36			X	X		X	X	X	X	X	X	
E 1 x 4	36				X								
E 1 x 6	36		X		X								
E 1 x 8	36		X		X								

BLOCKS						
Profile	Page #	PINE	MDF	OAK	POPLR	
<b>PLINTH BLOCKS</b>						
334	39		X			
P 358	39				X	
438	39		X			
742	39	X		X		
887	39	X		X		
916	39			X		
917	39	X		X		

BLOCKS						
Profile	Page #	PINE	MDF	OAK	POPLR	
<b>ROSETTE</b>						
3	38		X			
334	38		X			
P 358	38				X	
438	38		X			
642	38	X		X		
734	38	X		X		
871	38	X		X		
915	38	X		X		
<b>BASE BLOCKS</b>						
9 (OS)	38		X			
9 (IS)	38		X			
P 808	38				X	
P 813	38				X	
8920 (OS)	38	X				
8951 (IS)	38	X				

Profile	Page #	FJBAR	FJPMDF	FJPCC	FJDP	PINE	PINEV	MDF	BIRVN	WBIRVN	OAKVN	OAKOV	WOAKVN	POPP
<b>FLAT JAMBS, 6-8</b>														
11/16 x 4-9/16, 81" BD	37	X	X*	X			X*	X	X	X	X	X	X	
11/16 x 4-9/16, 81" BD Fluted	37		X											
11/16 x 4-9/16	37			X										
11/16 x 6-9/16, 81" BD	37			X										
11/16 x 4-5/8, 81" BD	37		X											X
11/16 x 4-5/8, 81-3/8" BD	37				X									
11/16 x 4-7/8, 81" BD	37		X											
11/16 x 5, 81" BD	37				X									
11/16 x 5-1/4, 81" BD	37					X								
<b>FLAT JAMBS, 8-0</b>														
11/16 x 4-5/8, 97" BD	37				X									X
11/16 x 4-7/8, 97" BD	37				X									
11/16 x 5, 97" BD	37				X									
<b>SPLIT JAMB, 1-1/16 X 4-9/16</b>														
2-3/4 FM x 2-1/4 M, 6-8	37		X			X								
2-3/4 FM x 2-1/2 M, 6-8	37		X											

\*3-0 Set Available

Empire's fine product selection extends well beyond mouldings. We also distribute quality columns, stair parts, flexible mouldings, PVC mouldings, boards, and decorative wood accessories.



For homeowners, builders and architects who will not settle for anything less than the finest materials and craftsmanship,

Turncraft offers the architectural columns, posts and railings of choice. Beautiful. Durable. Versatile. Functional. Available in classic as well as contemporary choices to complement any style.



L.J. Smith products are defined by their unique design - providing uncompromising durability and good looks. The exclusive features of our designs, including our patented Conect-A-Kit® system, result in unsurpassed strength and the benefits are simply endless. Nowhere will you find a selection that comes close to the vast array of styles available from L.J. Smith.



Beautiful Solutions™ moulding, once reserved for the interior of homes, are now front and center to add classic, chic, or casual innovation to any style home. Royal Decorative PVC Mouldings allow architects, builders, remodelers, and replacement contractors to add upgrades

which increase value, enhance curb appeal and lessen maintenance long-term.

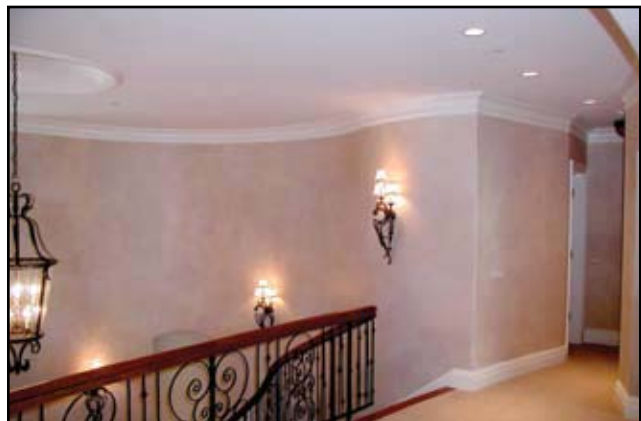

Intricate mouldings that arch effortlessly over doorways and windows. Customized and affordable accents that conform

to rounded walls and surfaces. If it can be imagined, Carter Millwork can produce it. Carter Millwork moulding and trim is made of polyurethane material - a strong, long-lasting and cost-effective alternative to wood and polyester products. Each piece is individually inspected to ensure compliance to exacting quality standards.

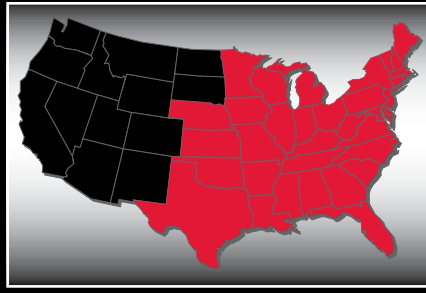

# **E**mpire<sup>®</sup> moulding

## **Zeeland Distribution Center**

P.O. Box 17

8181 Logistic Drive

Zeeland, MI 49464

Phone: (800) 253-9000

Fax: (800) 748-7670

[www.empireco.com](http://www.empireco.com)

© 2008 EMPIRE CO. E1-PG-07-08

Empire reserves the right to make changes to the products listed in this catalog without notice and without responsibility for existing units.

Drawings may not be to exact scale.